

V40HL™, V50HL™
16/8, 16-BIT MICROPROCESSOR

DESCRIPTION

The μ PD70208H (V40HL) is a high-speed, low-power 16-/8-bit microprocessor based on the μ PD70208 (V40™) with 16-bit architecture, 8-bit data bus, and general-purpose peripheral functions.

The μ PD70216H (V50HL) is a high-speed, low-power 16-bit microprocessor based on the μ PD70216 (V50™) with 16-bit architecture, 16-bit data bus, and general-purpose peripheral functions.

The V40HL and V50HL offer 20 MHz operation, and in addition to the conventional standby functions, also allows the clock to be stopped by the use of fully static internal circuitry, thus achieving greatly reduced power consumption. It is also capable of 3 V operation in addition to the previous 5 V operation, making it ideally suited to battery driven systems.

Details are given in the following manuals. Be sure to read when carrying out design work.

- **V40HL, V50HL User's Manual – Hardware (U11610E)**
- **16-bit V series™ User's Manual – Instruction (U11301J: Japanese version)**

FEATURES

- High-speed, low-power version of V40 and V50
- High-performance CPU (V20™/V30™ software compatible)
 - Minimum instruction execution time: 100 ns (20 MHz, 5 V)
200 ns (10 MHz, 3 V)
 - Memory addressing space: 1M bytes
 - High-speed multiply/divide instructions: 0.95 to 2.8 μ s (20 MHz, 5 V)
1.9 to 5.6 μ s (10 MHz, 3 V)
 - Maskable (ICU) & non-maskable (NMI) interrupt inputs
 - μ PD8080AF emulation function
 - Standby functions, clock stoppage capability
- Standard peripheral LSI functions on chip
 - Clock generator (CG)
 - Programmable wait control unit (WCU)
 - Refresh control unit (REFU)
 - Timer/counter unit (TCU) ... μ PD71054 subset
 - Serial control unit (SCU) ... μ PD71051 subset
 - Interrupt control unit (ICU) ... μ PD71059 subset
 - DMA control unit (DMAU) ... μ PD71071/71037 subset (functions of either selectable)
- Operating frequency: 10/12.5/16/20 MHz (at 5 V, with 20/25/32/40 MHz supplied externally)
5/6.25/8/10 MHz (at 3 V, with 10/12.5/16/20 MHz supplied externally)

The information in this document is subject to change without notice. Before using this document, please confirm that this is the latest version.

Not all devices/types available in every country. Please check with local NEC representative for availability and additional information.

ORDERING INFORMATION

(1) V40HL

Part Number	Package	Max. Operating Frequency (MHz)
μ PD70208HGF-10-3B9	80-pin plastic QFP (14 × 20 mm) (Resin thickness 2.7 mm)	10
μ PD70208HGF-12-3B9	80-pin plastic QFP (14 × 20 mm) (Resin thickness 2.7 mm)	12.5
μ PD70208HGF-16-3B9	80-pin plastic QFP (14 × 20 mm) (Resin thickness 2.7 mm)	16
μ PD70208HGF-20-3B9	80-pin plastic QFP (14 × 20 mm) (Resin thickness 2.7 mm)	20
μ PD70208H GK-10-9EU	80-pin plastic TQFP (Fine pitch) (12 × 12 mm) (Resin thickness 1.0 mm)	10
μ PD70208H GK-12-9EU	80-pin plastic TQFP (Fine pitch) (12 × 12 mm) (Resin thickness 1.0 mm)	12.5
μ PD70208H GK-16-9EU	80-pin plastic TQFP (Fine pitch) (12 × 12 mm) (Resin thickness 1.0 mm)	16
μ PD70208H GK-20-9EU	80-pin plastic TQFP (Fine pitch) (12 × 12 mm) (Resin thickness 1.0 mm)	20
μ PD70208HLP-10	68-pin plastic QFJ (950 × 950 mil)	10
μ PD70208HLP-12	68-pin plastic QFJ (950 × 950 mil)	12.5
μ PD70208HLP-16	68-pin plastic QFJ (950 × 950 mil)	16
μ PD70208HLP-20	68-pin plastic QFJ (950 × 950 mil)	20

(2) V50HL

Part Number	Package	Max. Operating Frequency (MHz)
μ PD70216HGF-10-3B9	80-pin plastic QFP (14 × 20 mm) (Resin thickness 2.7 mm)	10
μ PD70216HGF-12-3B9	80-pin plastic QFP (14 × 20 mm) (Resin thickness 2.7 mm)	12.5
μ PD70216HGF-16-3B9	80-pin plastic QFP (14 × 20 mm) (Resin thickness 2.7 mm)	16
μ PD70216HGF-20-3B9	80-pin plastic QFP (14 × 20 mm) (Resin thickness 2.7 mm)	20
μ PD70216H GK-10-9EU	80-pin plastic TQFP (Fine pitch) (12 × 12 mm) (Resin thickness 1.0 mm)	10
μ PD70216H GK-12-9EU	80-pin plastic TQFP (Fine pitch) (12 × 12 mm) (Resin thickness 1.0 mm)	12.5
μ PD70216H GK-16-9EU	80-pin plastic TQFP (Fine pitch) (12 × 12 mm) (Resin thickness 1.0 mm)	16
μ PD70216H GK-20-9EU	80-pin plastic TQFP (Fine pitch) (12 × 12 mm) (Resin thickness 1.0 mm)	20
μ PD70216HLP-10	68-pin plastic QFJ (950 × 950 mil)	10
μ PD70216HLP-12	68-pin plastic QFJ (950 × 950 mil)	12.5
μ PD70216HLP-16	68-pin plastic QFJ (950 × 950 mil)	16
μ PD70216HLP-20	68-pin plastic QFJ (950 × 950 mil)	20

PIN CONFIGURATION (Top View)

(1) V40HL

- 80-pin Plastic QFP (14 × 20 mm)

μPD70208HGF-10-3B9

μPD70208HGF-12-3B9

μPD70208HGF-16-3B9

μPD70208HGF-20-3B9

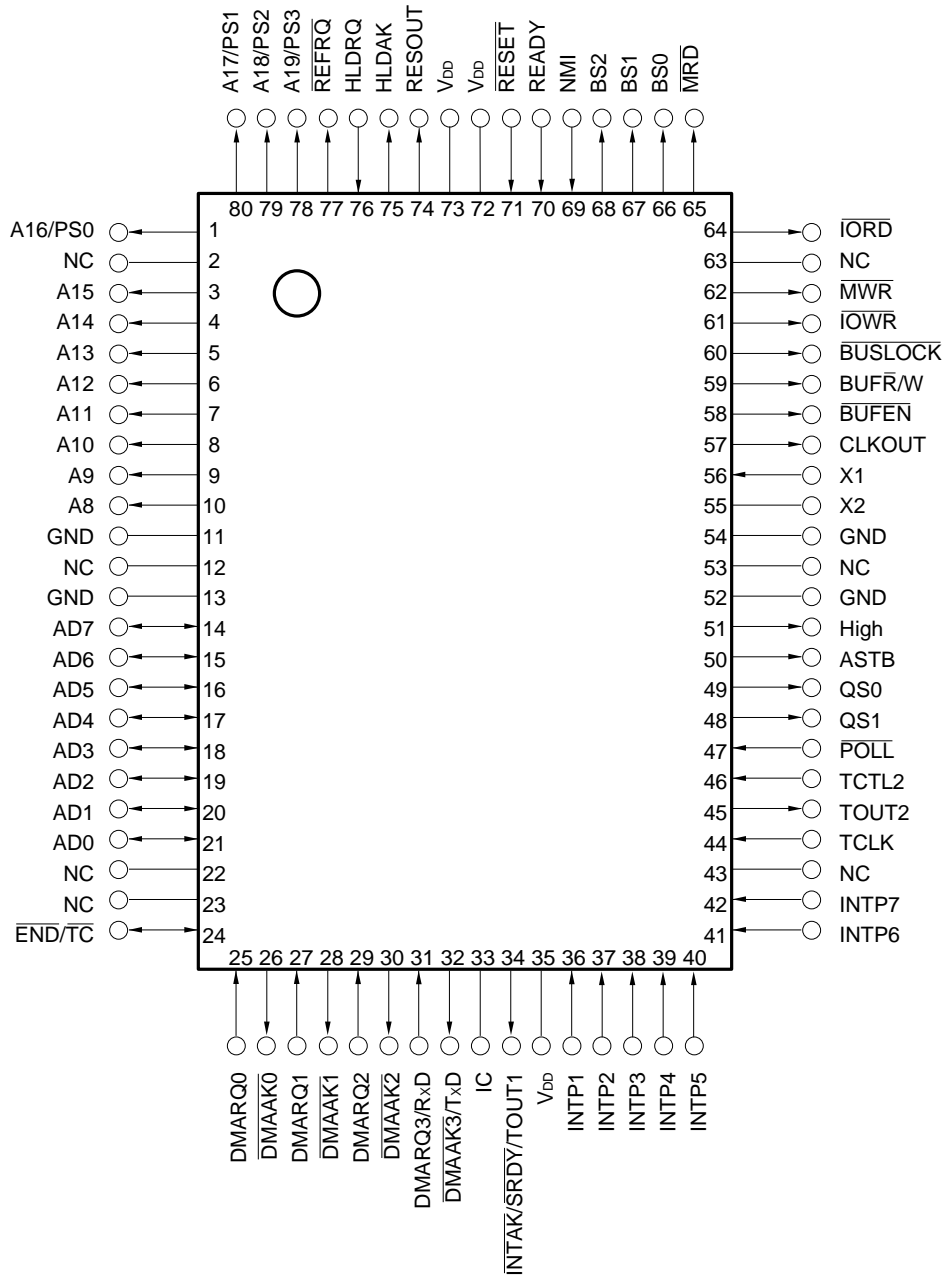

Caution Leave IC pin open.

- 80-pin Plastic TQFP (Fine pitch) (12 × 12 mm)
 - μPD70208HGK-10-9EU
 - μPD70208HGK-12-9EU
 - μPD70208HGK-16-9EU
 - μPD70208HGK-20-9EU

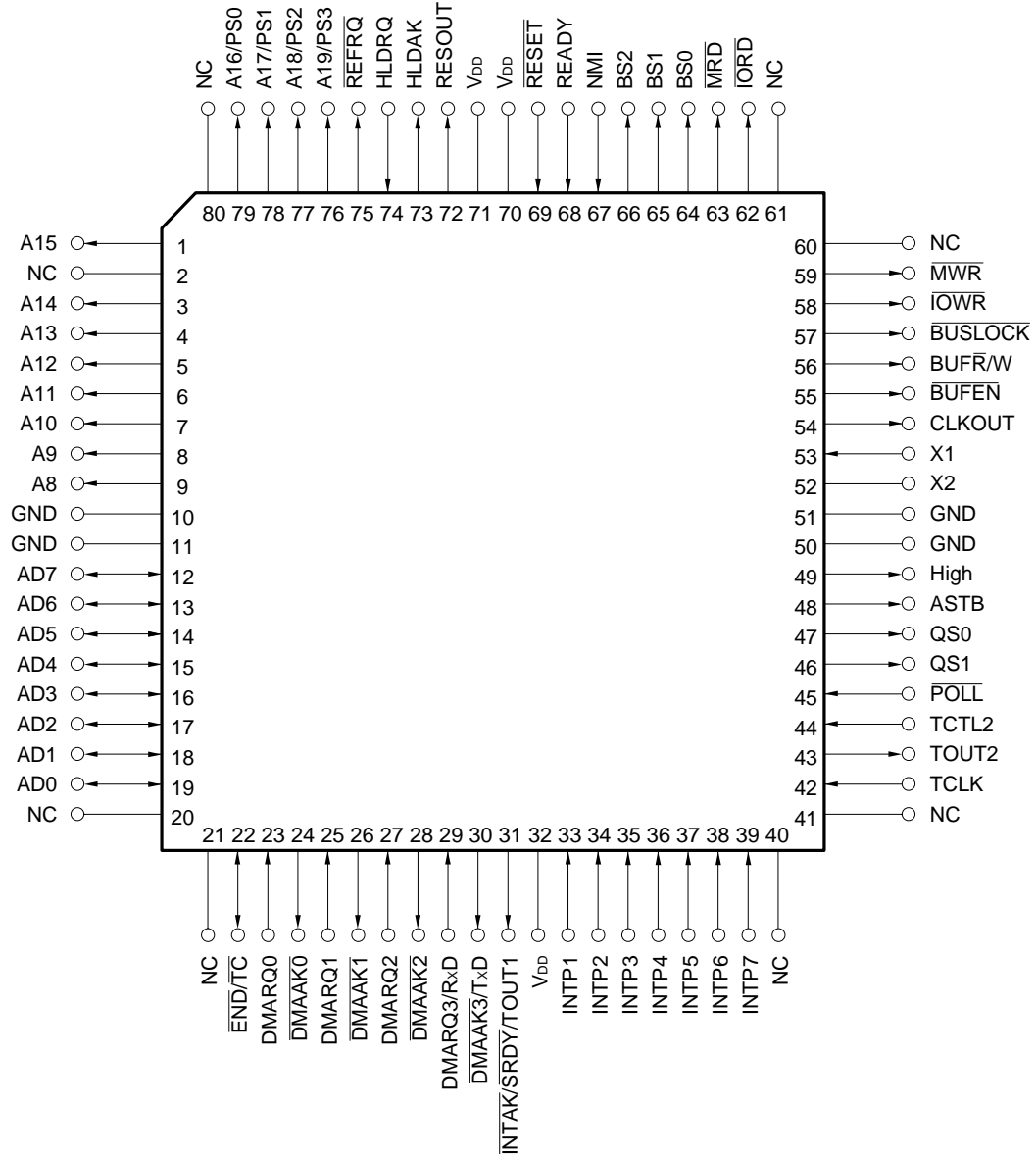

- 68-pin Plastic QFJ (950 × 950 mil)
 - μPD70208HLP-10
 - μPD70208HLP-12
 - μPD70208HLP-16
 - μPD70208HLP-20

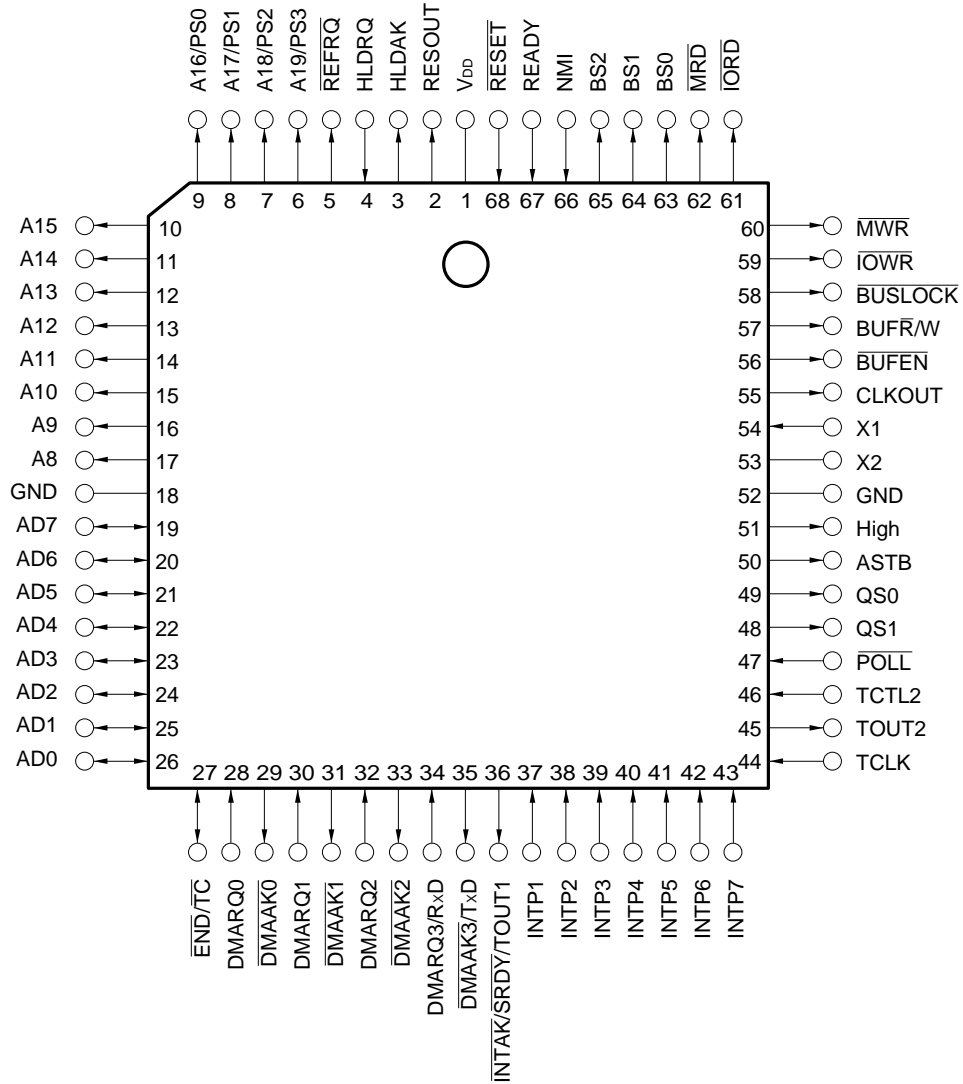

(2) V50HL

- 80-pin Plastic QFP (14 × 20 mm)

μPD70216HGF-10-3B9

μPD70216HGF-12-3B9

μPD70216HGF-16-3B9

μPD70216HGF-20-3B9

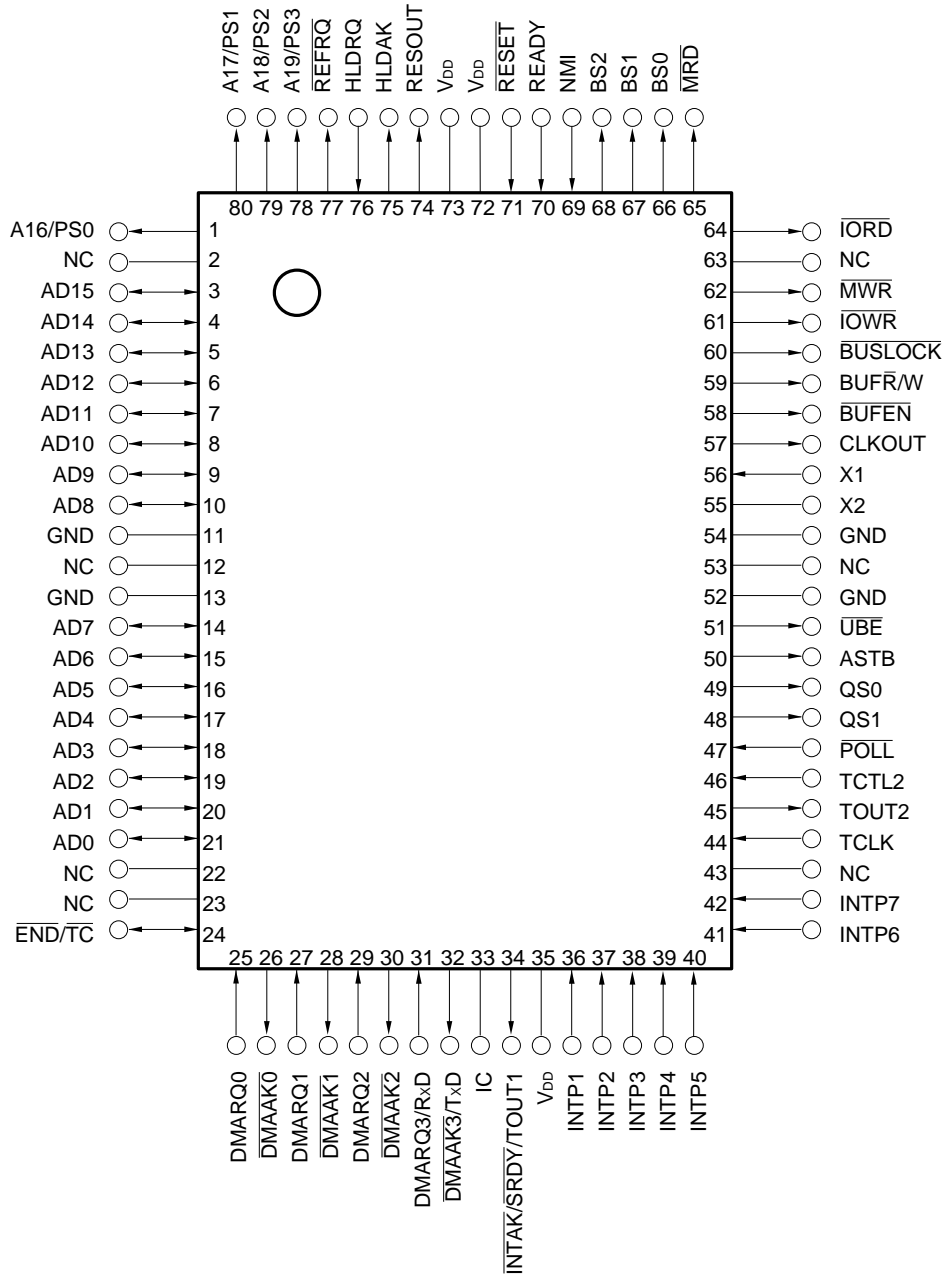

Caution Leave IC pin open.

• 80-pin Plastic TQFP (Fine pitch) (12 × 12 mm)

μPD70216HGK-10-9EU

μPD70216HGK-12-9EU

μPD70216HGK-16-9EU

μPD70216HGK-20-9EU

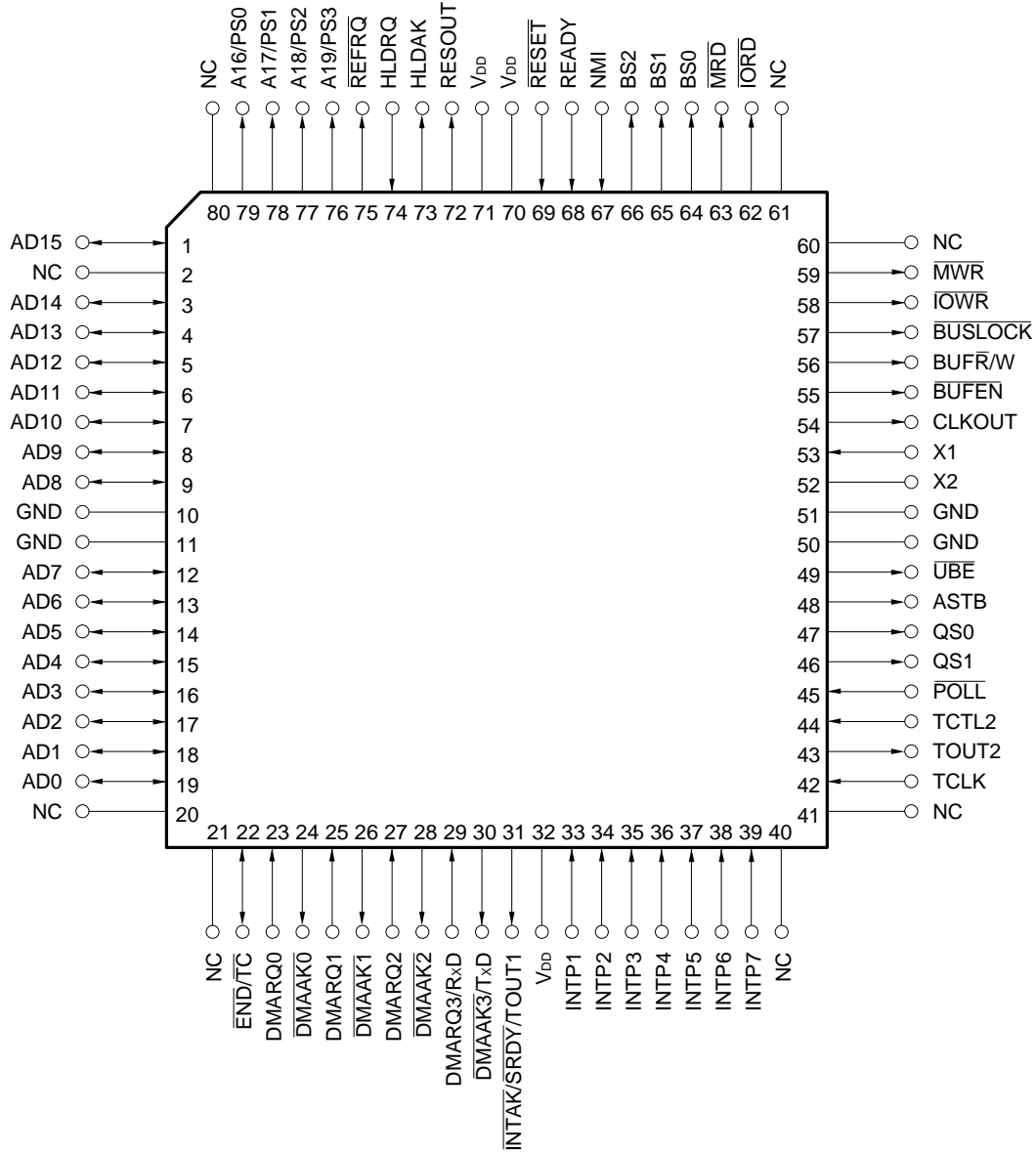

- 68-pin Plastic QFJ (950 × 950 mil)
 - μPD70216HLP-10
 - μPD70216HLP-12
 - μPD70216HLP-16
 - μPD70216HLP-20

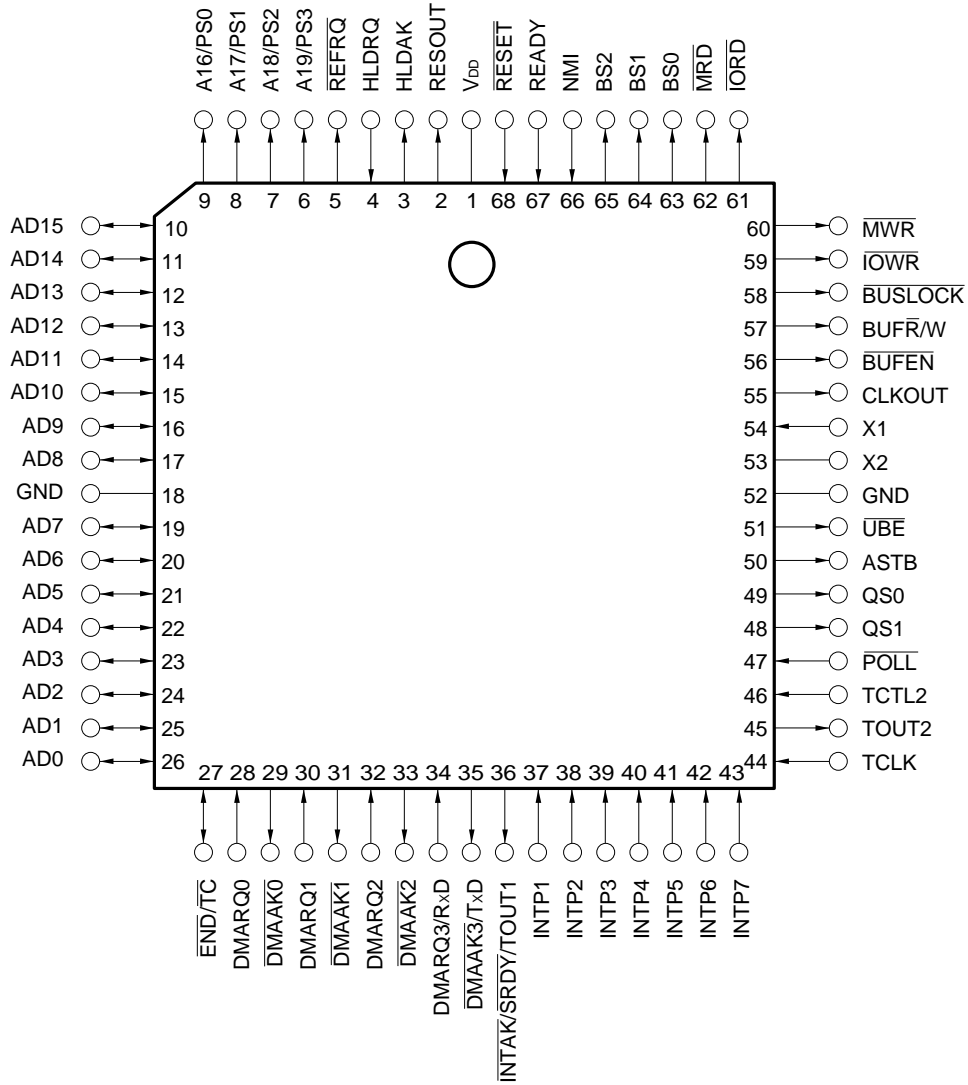

PIN NAMES

A8-A15	: Address Bus
A16/PS0-A19/PS3	: Address/Processor Status
AD0-AD15	: Address Bus/Data Bus
ASTB	: Address Strobe
BS0-BS2	: Bus Status
BUFEN	: Buffer Enable
BUFR/W	: Buffer Read/Write
BUSLOCK	: Bus Lock
CLKOUT	: Clock Output
DMAAK0-DMAAK2	: DMA Acknowledge
DMAAK3/TxD	: DMA Acknowledge/Transmit Data
DMARQ0-DMARQ2	: DMA Request
DMARQ3/RxD	: DMA Request/Receive Data
END/TC	: End/Terminal Count
GND	: Ground
High	: High Level Output
HLDK	: Hold Acknowledge
HLDRQ	: Hold Request
IC	: Internally Connected
INTAK/SRDY/TOUT1	: Interrupt Acknowledge/Serial Ready/Timer Output 1
INTP1-INTP7	: Interrupt Request from Peripherals
$\overline{\text{IOR}}$: I/O Read
$\overline{\text{IOW}}$: I/O Write
$\overline{\text{MRD}}$: Memory Read
$\overline{\text{MWR}}$: Memory Write
NC	: No Connection
NMI	: Non-Maskable Interrupt Request
POLL	: Poll
QS0, QS1	: Queue Status
READY	: Ready
$\overline{\text{REFRQ}}$: Refresh Request
RESET	: Reset
RESOUT	: Reset Output
TCLK	: Timer Clock
TCTL2	: Timer Control 2
TOUT2	: Timer Output 2
UBE	: Upper Byte Enable
V _{DD}	: Power Supply
X1, X2	: Crystal

BLOCK DIAGRAM

(1) V40HL

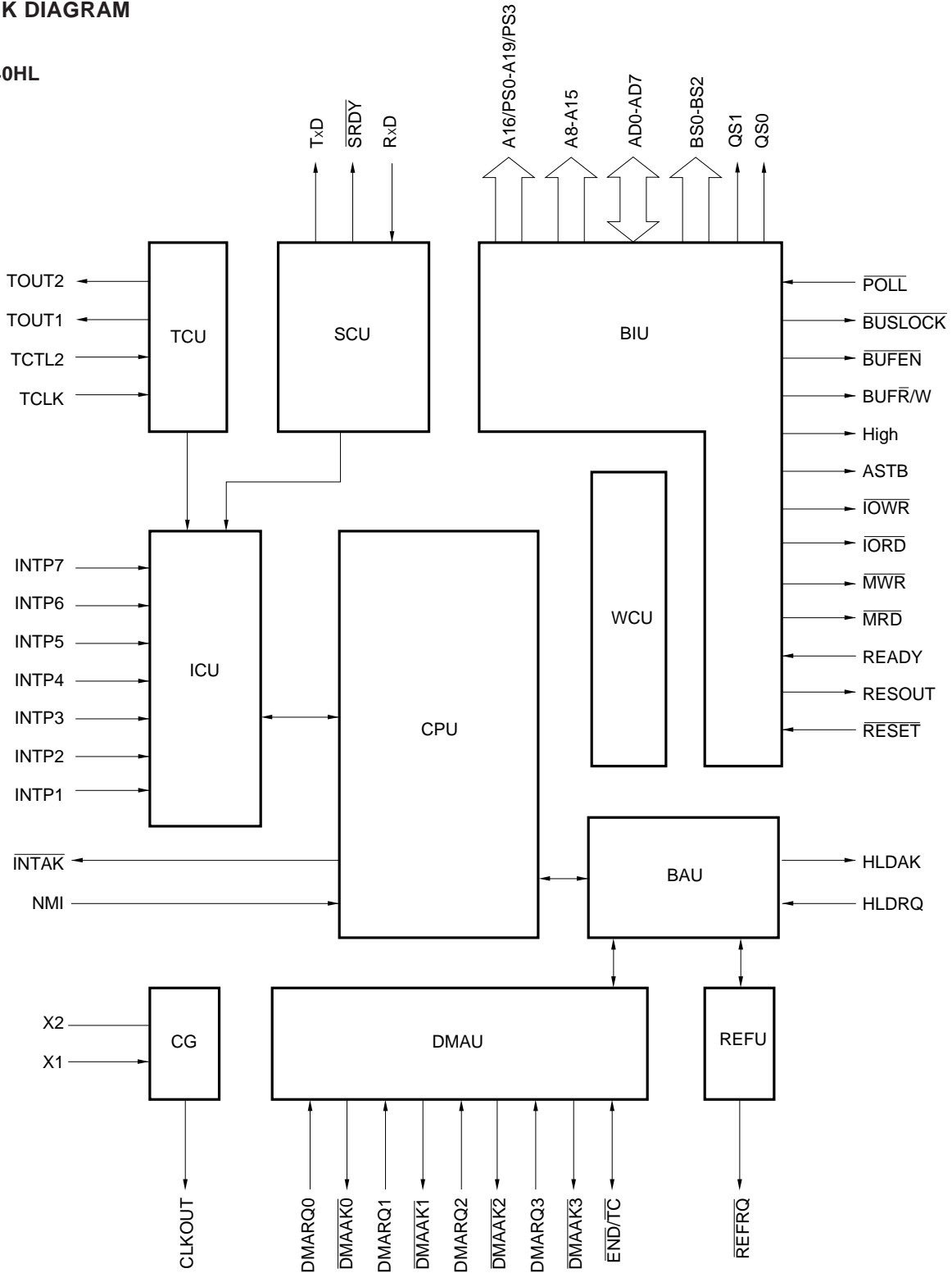

- | | |
|-------------------------------|------------------------------|
| CPU : Central Processing Unit | REFU : Refresh Control Unit |
| CG : Clock Generator | TCU : Timer/Count Unit |
| BIU : Bus Interface Unit | SCU : Serial Control Unit |
| BAU : Bus Arbitration Unit | ICU : Interrupt Control Unit |
| WCU : Wait Control Unit | DMAU : DMA Control Unit |

(2) V50HL

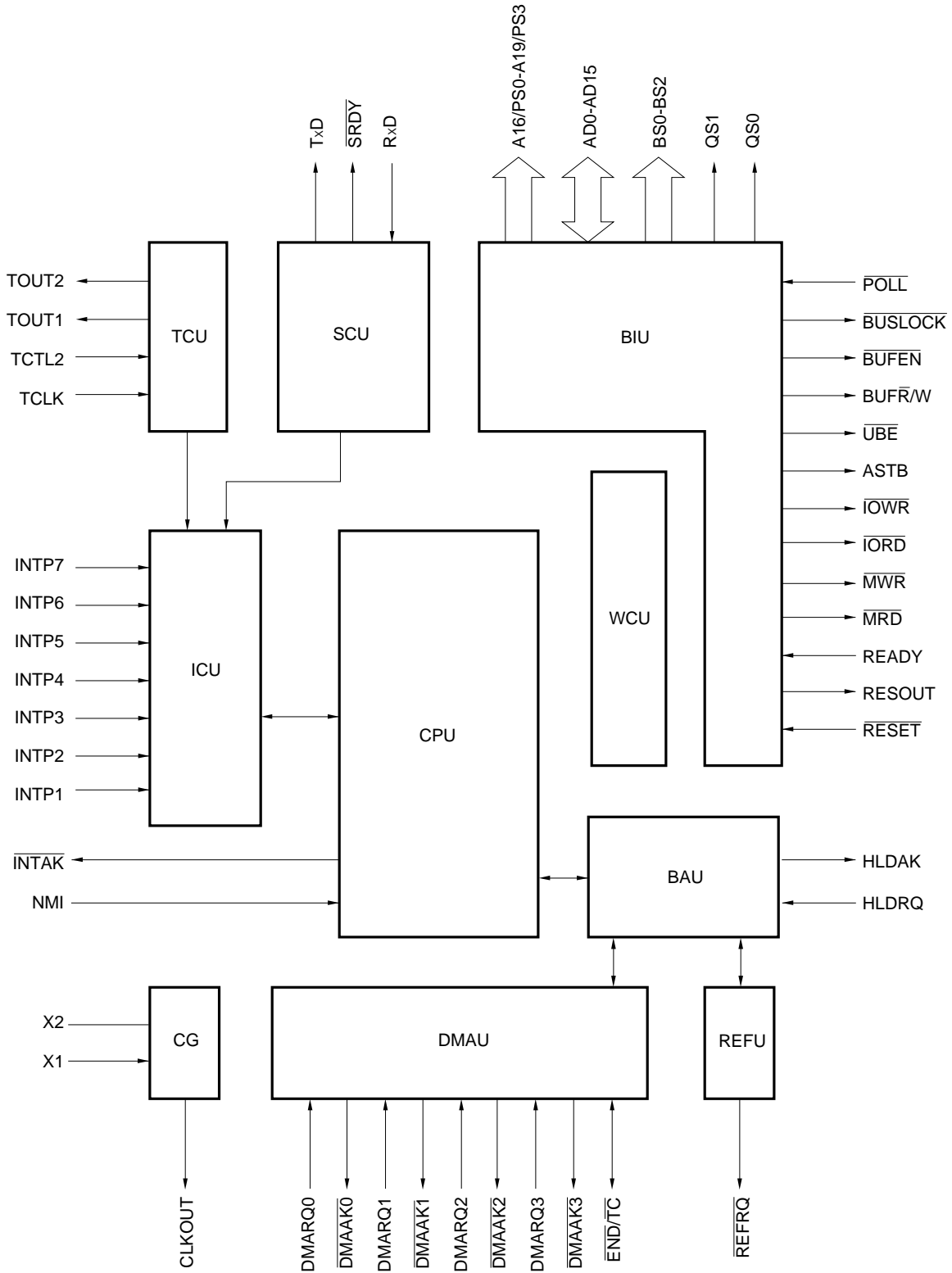

DIFFERENCES FROM V40 AND V50

Item		V40HL, V50HL	V40, V50
Operating supply voltage		3 V, 5 V	5 V
Operating frequency	V _{DD} = 5 V	MAX. : 10, 12.5, 16, 20 MHz MIN. : DC	MAX. : 8, 10 MHz MIN. : 2 MHz
	V _{DD} = 3 V	MAX. : 5, 6.25, 8, 10 MHz MIN. : DC	No operation
Clock generator (CG)		Variable scaling factor	Fixed scaling factor
		Variable instruction cycle time	Fixed instruction cycle time
		Maximum input frequency: 40 MHz	Maximum input frequency: 20 MHz
Internal I/O relocation function		Switchable 8-bit boundary or 16-bit boundary relocation function	V40: Relocation possible on 8-bit boundary V50: Relocation possible on 16-bit boundary
Wait control unit (WCU)		Memory space: 5 divisions ^{Note 1}	Memory space: 3 divisions
		I/O space: 3 divisions ^{Note 2}	I/O space: Not divided
Refresh control unit (REFU)		Refresh address: 16 bits	Refresh address: 9 bits
		$\overline{\text{REFRQ}}$ extended timing supported	No $\overline{\text{REFRQ}}$ extended timing
Serial control unit (SCU)		Dedicated baud rate generator incorporated	No dedicated baud rate generator incorporated
DMA control unit (DMAU)		μPD71071/71037 subset (either function selectable)	μPD71071 subset
Standby functions		HALT mode, STOP mode	HALT mode only

- Notes**
1. Divided into 3 when a reset is performed.
 2. Not divided when a reset is performed.

CONTENTS

1. PIN FUNCTIONS	15
1.1 LIST OF PIN FUNCTIONS	15
1.2 PROCESSING OF UNUSED PINS	17
2. MEMORY AND I/O CONFIGURATION	19
2.1 MEMORY SPACE	19
2.2 I/O SPACE	21
3. CPU	22
4. CG (CLOCK GENERATOR)	24
5. BIU (BUS INTERFACE UNIT)	24
6. BAU (BUS ARBITRATION UNIT)	25
7. WCU (WAIT CONTROL UNIT)	27
7.1 FEATURES	27
7.2 RELATION BETWEEN WCU AND READY PIN	28
8. REFU (REFRESH CONTROL UNIT)	29
8.1 FEATURES	29
8.2 REFRESH OPERATIONS	29
9. TCU (TIMER/COUNTER UNIT)	30
9.1 FEATURES	30
9.2 TCU INTERNAL BLOCK DIAGRAM	30
10. SCU (SERIAL CONTROL UNIT)	31
10.1 FEATURES	31
10.2 SCU INTERNAL BLOCK DIAGRAM	31
11. ICU (INTERRUPT CONTROL UNIT)	32
11.1 FEATURES	32
11.2 ICU INTERNAL BLOCK DIAGRAM	32
12. DMAU (DMA CONTROL UNIT)	33
12.1 FEATURES	33
12.2 DMAU INTERNAL BLOCK DIAGRAM	33
13. STANDBY FUNCTIONS	34
14. RESET OPERATION	34
15. INSTRUCTION SET	35

16. ELECTRICAL SPECIFICATIONS	66
16.1 AT 5 V OPERATION	66
16.2 AT 3 V OPERATION	75
17. PACKAGE DRAWINGS	100
18. RECOMMENDED SOLDERING CONDITIONS	103

1. PIN FUNCTIONS

1.1 LIST OF PIN FUNCTIONS

Pin Name	Input/Output	Function
AD0 to AD15 ^{Note 1, 3}	3-state I/O	Time-division address/data bus
AD0 to AD7 ^{Note 2, 3}	3-state I/O	Time-division address/data bus
A8 to A15 ^{Note 2, 3}	3-state output	Address bus
A16/PS0 to A19/PS3 ^{Note 3}	3-state output	Time-division address/processor status
REFRQ	Output	Refresh request
HLDRQ	Input	Bus hold request
HLDACK	Output	Bus hold acknowledge
RESET	Input	Reset
RESOUT	Output	System reset output
READY	Input	Bus cycle end
NMI	Input	Non-maskable interrupt
MRD ^{Note 3}	3-state output	Memory read strobe
MWR ^{Note 3}	3-state output	Memory read strobe
IOR ^{Note 3}	3-state output	I/O read strobe
IOWR ^{Note 3}	3-state output	I/O write strobe
ASTB	Output	Address strobe
UBE ^{Note 1, 3}	3-state output	Data bus upper byte enable
High ^{Note 2}	3-state output	High level output
BUSLOCK ^{Note 3}	3-state output	Bus lock
POLL	Input	Floating-point operation processor polling
BUF \bar{R} /W ^{Note 3}	3-state output	Buffer read/write
BUFEN ^{Note 3}	3-state output	Buffer enable
X1	Input	Crystal/external clock
X2	—	
CLKOUT	Output	Clock output
BS0 to BS2 ^{Note 3}	3-state output	Bus status
QS0, QS1	Output	Queue status
TOUT2	Output	Timer 2 output
TCTL2	Input	Timer 2 control
TCLK	Input	Timer clock
INTP1 to INTP7	Input	Maskable interrupts
INTAK/ \bar{SRDY} /TOUT1	Output	Interrupt acknowledge/serial reception ready/timer 1 output

- Notes**
1. V50HL only
 2. V40HL only
 3. These pins are provided with a latch. Therefore, when they go into a high-impedance state, they hold the status before the high-impedance state until driven by an external device. It is not necessary to pull up or down the data bus. To invert the level of the pin that goes into a high-impedance state by an external device, a drive current higher than the latch invert current (I_{ILH} , I_{ILL}) is necessary.

Pin Name	Input/Output	Function
DMAAK3/TxD	Output	DMA acknowledge 3/serial transmit data
DMARQ3/RxD	Input	DMA request 3/serial receive data
$\overline{\text{DMAAK0}}$ to $\overline{\text{DMAAK2}}$	Output	DMA acknowledge
DMARQ0 to DMARQ2	Input	DMA request
$\overline{\text{END/TC}}$	I/O	DMA service forcible termination/DMA service completion
V _{DD}	—	Positive power supply pin
GND	—	Ground potential pin
IC	—	Internal connection pin (External connection impossible)

1.2 PROCESSING OF UNUSED PINS

Table 1-1 shows the processing (recommended connection) of the unused pins. Use of a resistor with a resistance of 1 to 10 kΩ is recommended to connect these pins to V_{DD} or GND via resistor.

Table 1-1. Processing of Unused Pins

Pin Name	Input/Output	Recommended Connection
AD0 to AD15 ^{Note 1}	3-state I/O	Open
AD0 to AD7 ^{Note 2}	3-state I/O	
A8 to A15 ^{Note 2}	3-state output	
A16/PS0 to A19/PS3	3-state output	
REFRQ	Output	
HLDRQ	Input	Connect to GND via resistor
HLDK	Output	Open
RESOUT	Output	Open
READY	Input	Connect to V _{DD} via resistor
NMI	Input	Connect to GND via resistor
MRD	3-state output	Open
MWR	3-state output	
IOR _D	3-state output	
IOWR	3-state output	
ASTB	Output	
UBE ^{Note 1}	3-state output	
High ^{Note 2}	Output	
BUSLOCK	3-state output	
POLL	Input	Connect to GND via resistor
BUFR/W	3-state output	Open
BUFEN	3-state output	
CLKOUT	Output	Open
BS0 to BS2	3-state output	
QS0, QS1	Output	
TOUT2	Output	
TCTL2	Input	Connect to GND via resistor
TCLK	Input	
INTP1 to INTP7	Input	Open
INTAK/SRDY/TOUT1	Output	
DMAAK3/TxD	Output	
DMARQ3/RxD	Input	Connect to GND via resistor
DMAAK0 to DMAAK2	Output	Open
DMARQ0 to DMARQ2	Input	Connect to GND via resistor
END/TC	I/O	Individually connect to V _{DD} via resistor

- Notes** 1. V50HL only
 2. V40HL only

Remark The circuit configuration of the latch is as illustrated below. To invert the level of the pin with a latch, a drive current higher than the latch invert current is necessary.

(1) Output pin

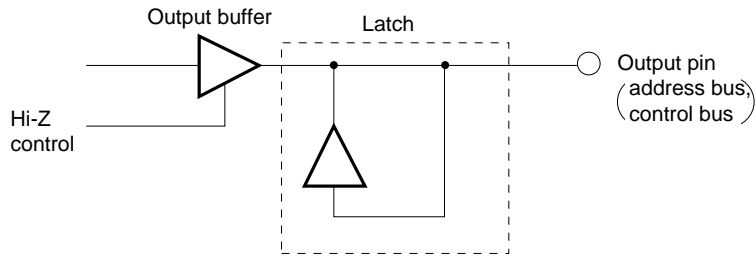

(2) I/O pin

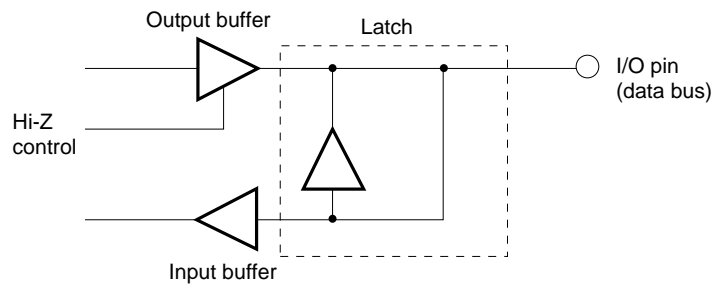

2. MEMORY AND I/O CONFIGURATION

2.1 MEMORY SPACE

The V40HL and V50HL can access a 1M-byte (512K-word) memory space.

Figure 2-1. Memory Map

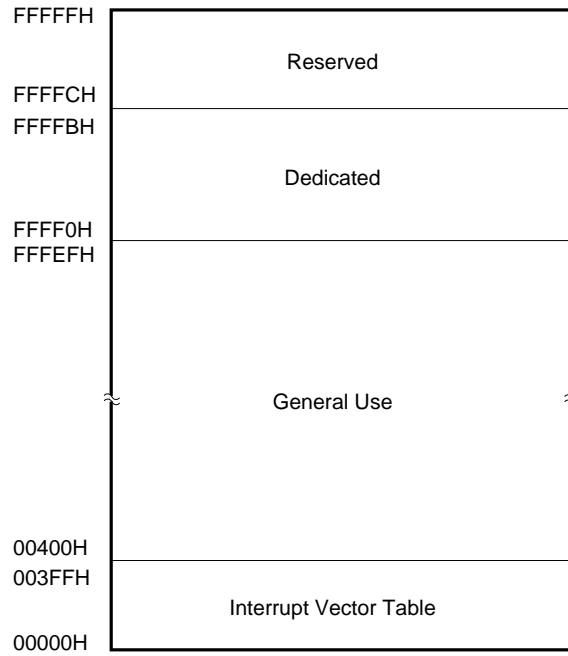

Figure 2-2. Interface with Memory (1/2)

(a) V40HL

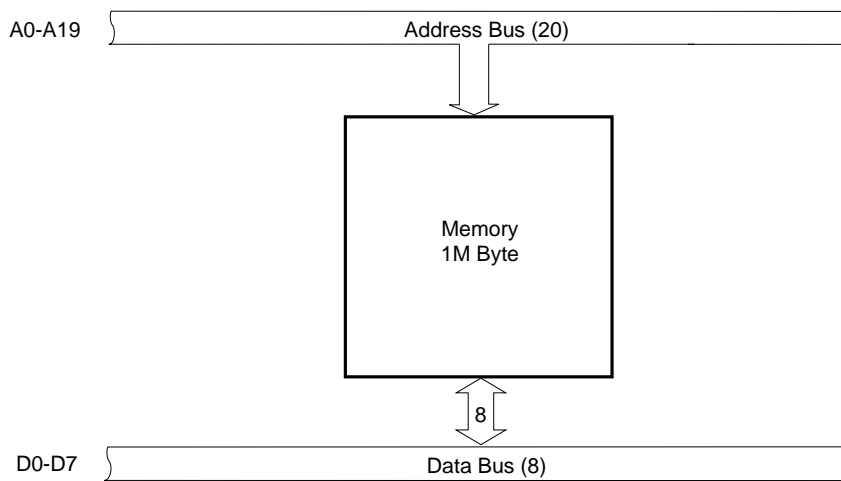
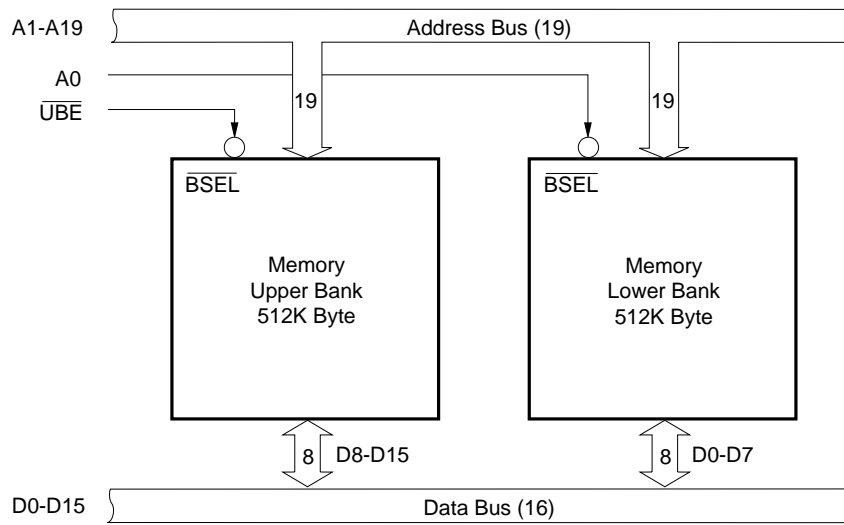

Figure 2-2. Interface with Memory (2/2)

(b) V50HL



2.2 I/O SPACE

In the V40HL and V50HL, I/Os up to 64K bytes (32K words) can be accessed in an area independent of the memory. The various on-chip peripheral LSIs are set by accessing the system I/O area.

Extended functions added to those of the V40 and V50 are mapped onto unused V40 and V50 registers and the reserved area.

The I/O map is shown in Figure 2-3.

Figure 2-3. I/O Map

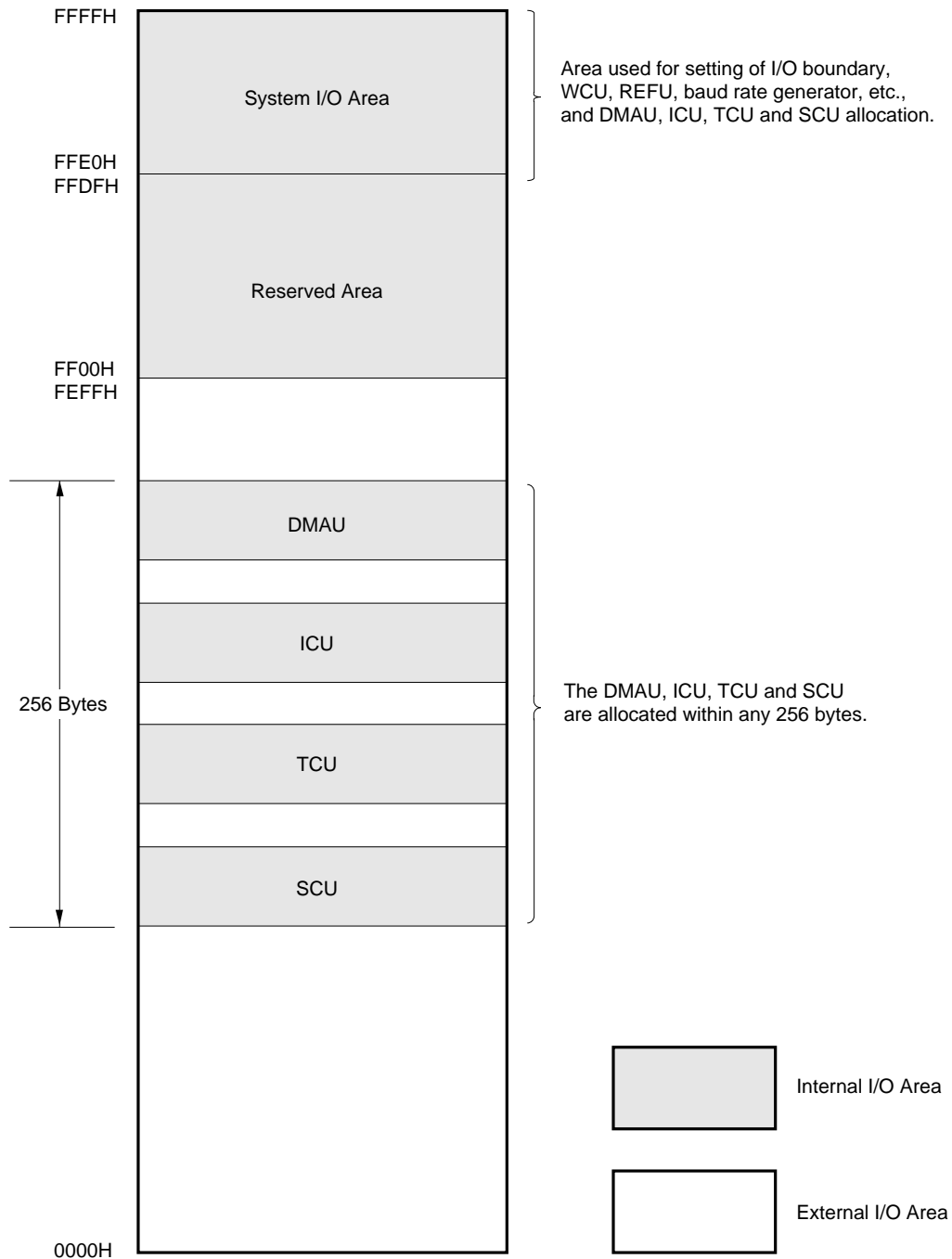

3. CPU

The CPU has the same functions as the V20HL™ and V30HL™. In hardware terms, there are some changes regarding the use of the bus with on-chip peripherals, but in software terms the CPU is fully compatible.

The internal block diagram of the CPU is shown in Figure 3-1.

Figure 3-1. Internal Block Diagram of CPU (1/2)

(a) V40HL

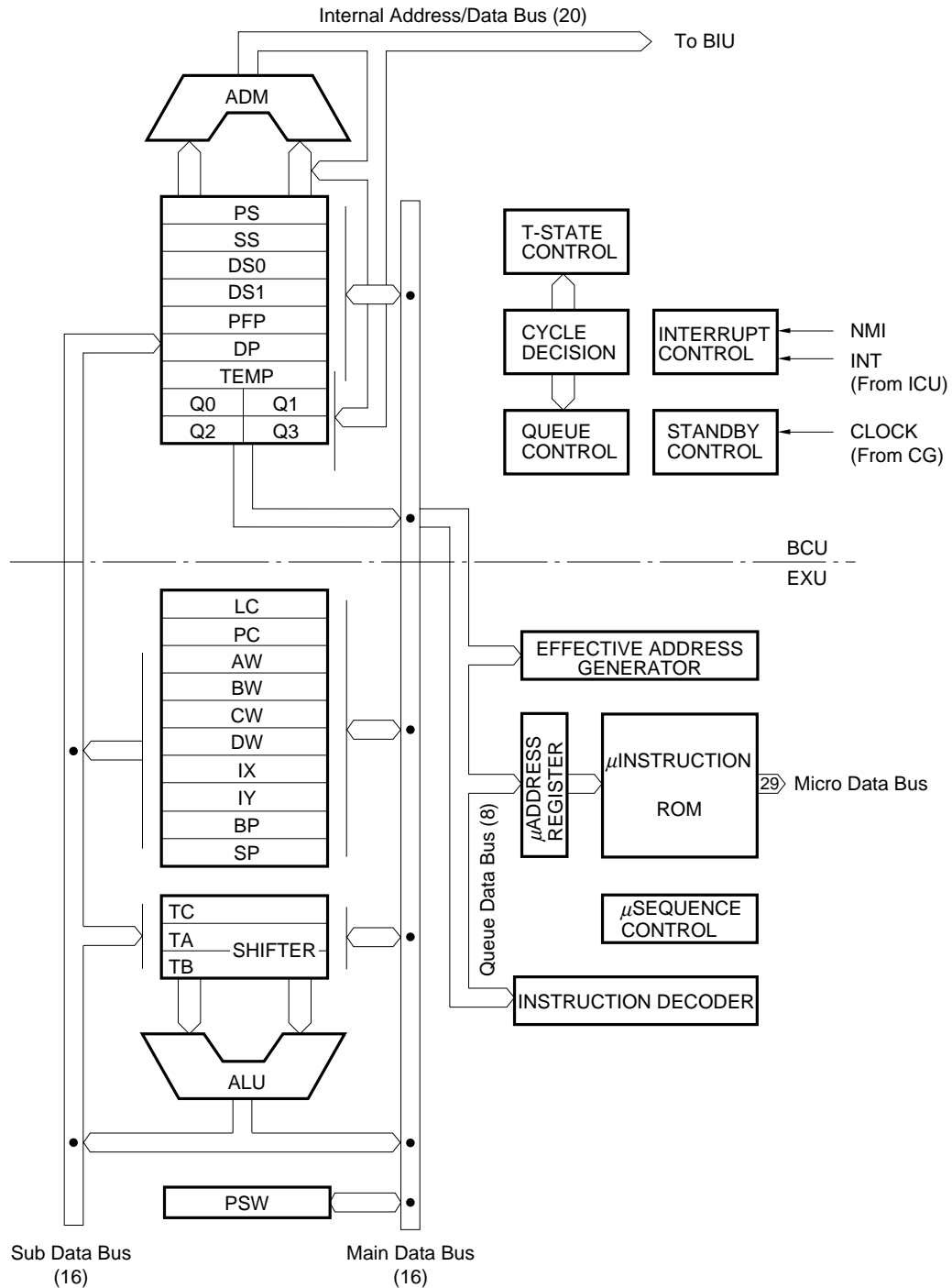
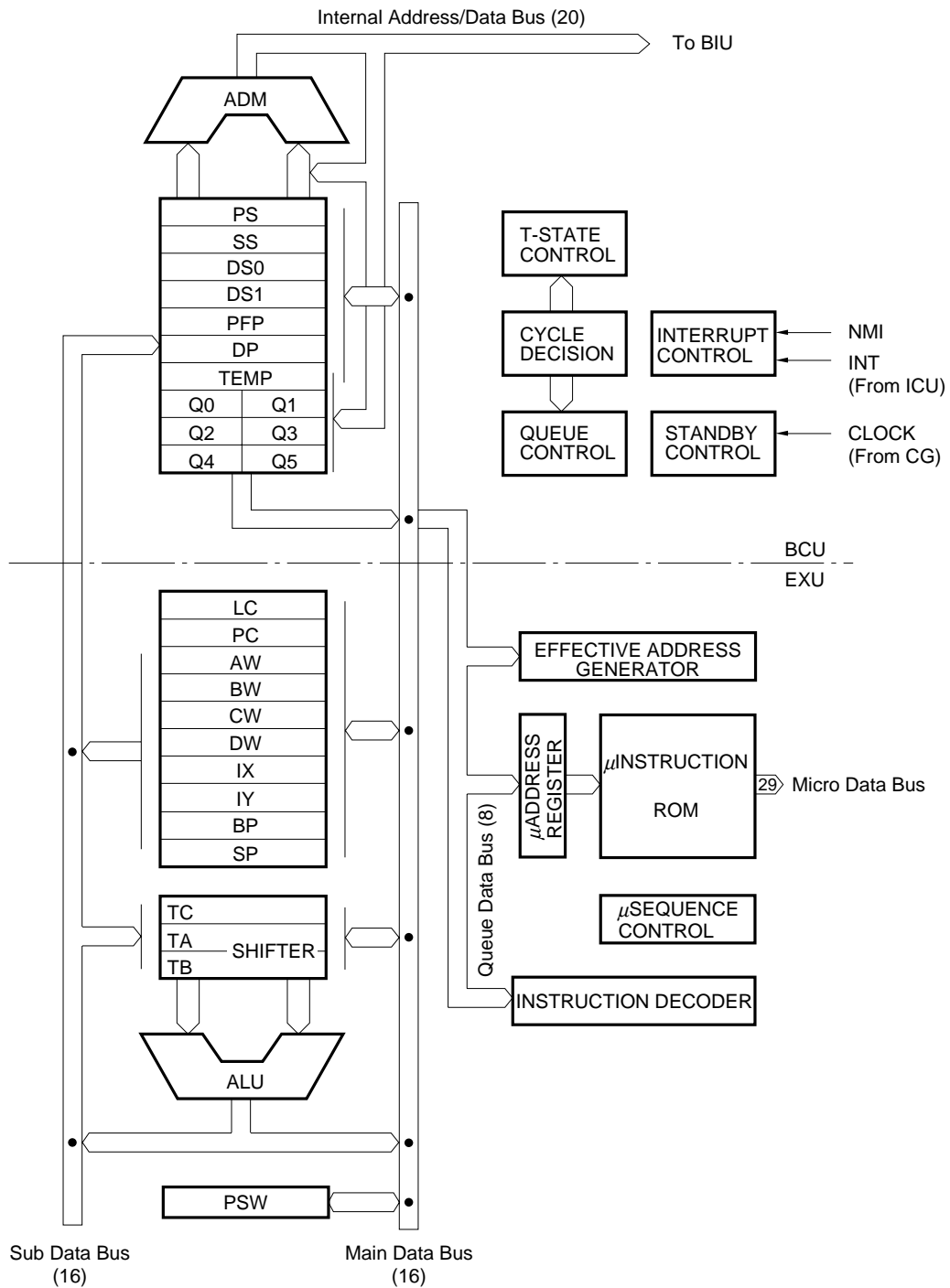

Figure 3-1. Internal Block Diagram of CPU (2/2)

(b) V50HL



4. CG (CLOCK GENERATOR)

The CG generates a clock at a frequency of 1/2, 1/4, 1/8 or 1/16 that of the crystal and oscillator connected to the X1 and X2 pins, supplies it as the CPU operating clock and outputs it externally as the CLKOUT pin output.

The interrupt cycle time can be changed according to the oscillator scaling factor. The scaling factor can be set by a system I/O area register.

Figure 4-1. Internal Block Diagram of CG

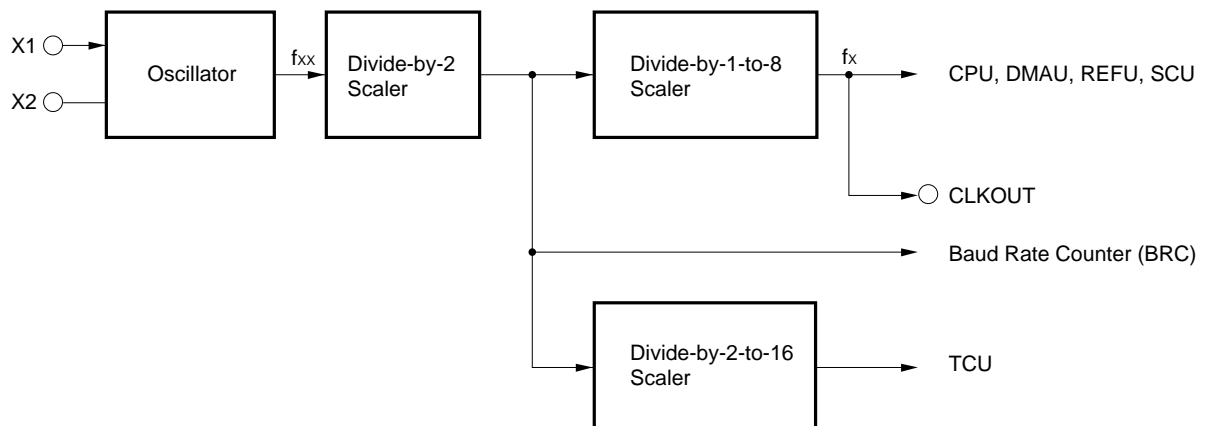

5. BIU (BUS INTERFACE UNIT)

The BIU controls the data bus, address bus and control bus pins. These buses are used by the CPU, DMAU (DMA control unit) and REFU (refresh control unit).

The BIU synchronizes the $\overline{\text{RESET}}$ input signal and READY input signal using the CLOCK signal generated by the clock generator (CG). In addition to being supplied to the inside of the V40HL and V50HL, the synchronized reset signal is also output externally from the RESOUT pin. The synchronized READY signal is supplied to the internal CPU, DMAU and REFU.

Figure 5-1. $\overline{\text{RESET}}$ and READY Signal Synchronization

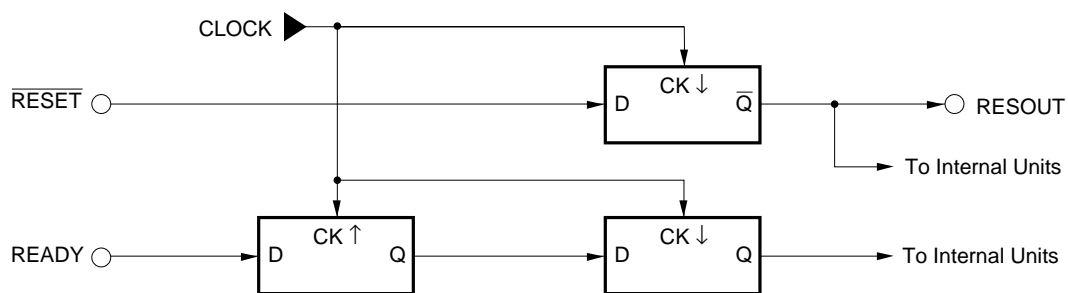

6. BAU (BUS ARBITRATION UNIT)

The BAU performs bus arbitration among bus masters.

A list of bus masters (units which can acquire the bus) is shown below.

Table 6-1. Bus Masters

Bus Master	Bus Cycle
CPU	Program fetch, data read/write
DMAU	DMA cycle
REFU	Refresh cycle
External bus master (HLDRQ pin input)	Bus cycle driven by external device

The relative priorities of the bus masters are shown below.

High	CPU (when BUSLOCK prefix is used)
↑	REFU (highest priority: when given number of requests are reached)
	DMAU
	HLDRQ pin
↓	CPU (normal CPU cycle)
Low	REFU (lowest priority: cycle steal)

BAU bus arbitration is performed as follows.

A bus master such as the CPU, DMAU, REFU, etc., incorporated in the V40HL and V50HL normally release the bus at the end of the bus cycle currently being executed, as shown in Figure 6-1. However, in the case of a bus master connected to the HLDRQ pin, or cascaded external DMA controllers, for instance, the situation is as shown in Figure 6-2. The V40HL and V50HL request return of the bus by inactivating the acknowledge signal (HLDAK), and on receiving this request, the external bus master holding the bus should release the bus by dropping the bus hold request signal (HLDRQ). The V40HL and V50HL-internal bus master with the highest priority is kept waiting until the bus hold request signal is dropped. This is called a bus wait operation.

Figure 6-1. Internal Bus Cycles

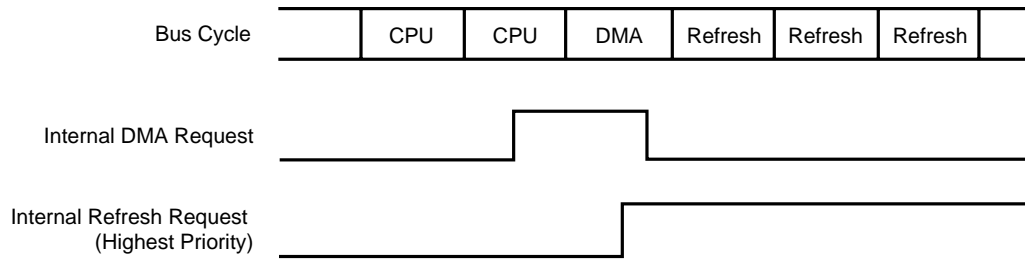
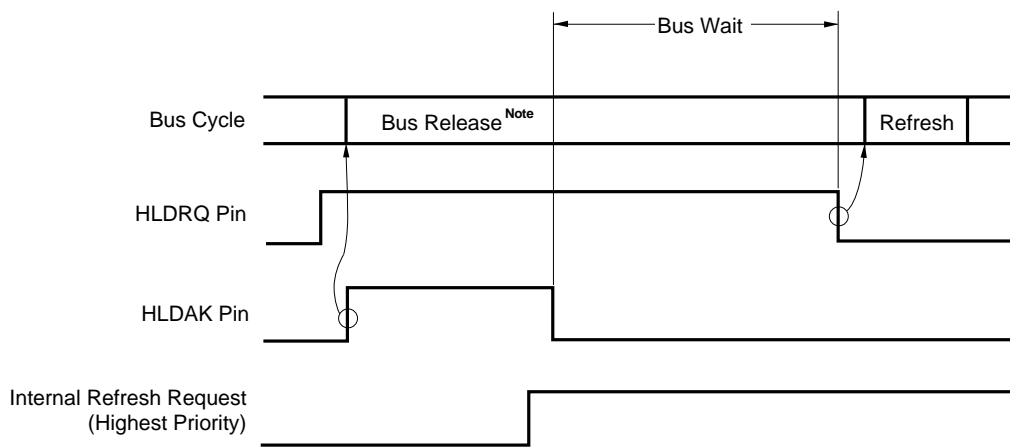

Figure 6-2. Bus Wait Operation



Note The period in which the external bus master which has been given the bus after its release by the V40HL and V50HL can use the bus.

7. WCU (WAIT CONTROL UNIT)

The WCU has the function of automatically inserting a wait state (TW) of 0 to 3 clock cycles in a CPU, DMAU or REFU bus cycle.

7.1 FEATURES

- Automatic setting of 0 to 3 waits for a CPU memory bus cycle
- 1M-byte memory space can be divided into 5
- 64K-byte I/O space can be divided into 3
- Automatic setting of 0 to 3 waits for an external I/O cycle
- Automatic setting of 0 to 3 waits for a DMA cycle
- Automatic setting of 0 to 3 waits for a refresh cycle
- Same as V40 and V50 directly after a reset (memory space divided into 3, no division of I/O space)

Figure 7-1. Example of Memory Space Division

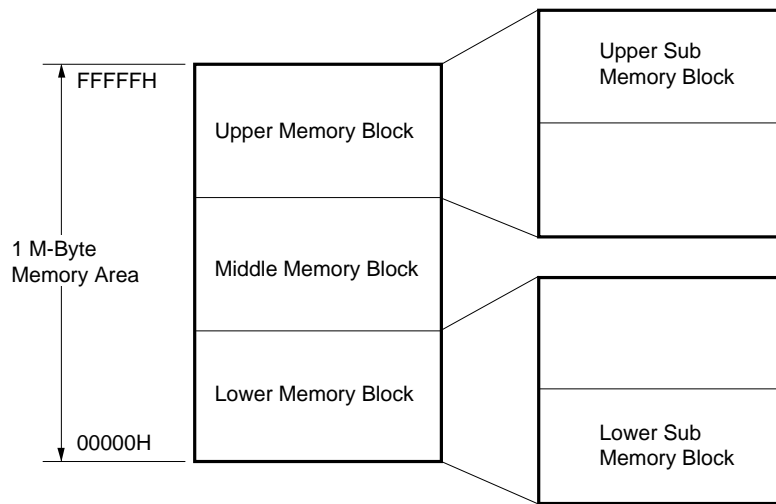

Remark The division specification and the size of each block are set by means of a system I/O area register.

Figure 7-2. Example of I/O Space Division

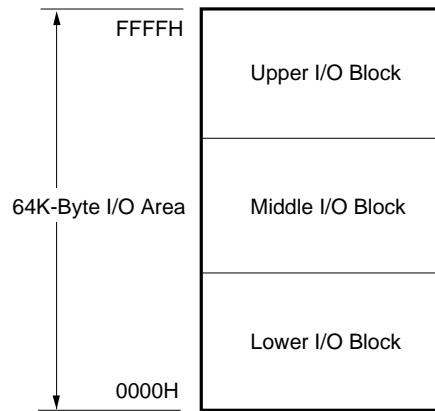

Remark The division specification and the size of each block are set by means of a system I/O area register.

7.2 RELATION BETWEEN WCU AND READY PIN

When wait cycles exceeding 3 clock cycles are necessary, the WCU and the READY signal pin can be used in combination. The number of wait cycles specified by the WCU set value or the number of wait cycles under READY control, whichever is larger, is inserted.

Figure 7-3. WCU and READY Control

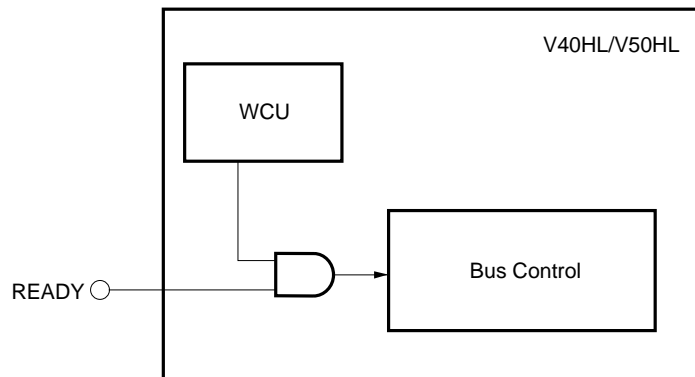

8. REFU (REFRESH CONTROL UNIT)

The REFU generates refresh cycles required for refreshing of external DRAM. Refresh enabling/disabling and the refresh interval can be set programmably.

8.1 FEATURES

- Lowest-priority refreshing/highest-priority refreshing
- 7-refresh queue
- 16-bit refresh address
- $\overline{\text{REFRQ}}$ extended timing supported ($\overline{\text{REFRQ}}$ active from T1 state)

8.2 REFRESH OPERATIONS

The REFU has two priorities. Normally, it has the lowest priority, and a refresh cycle cannot be started unless the bus is completely idle. However, if there are 7 or more pending refresh requests, it is given the highest priority, and it requests the bus master holding the bus to relinquish it. (See **6. BAU.**)

The refresh address is output on A0 to A15. Every refresh cycle the refresh address is incremented by 1 (for the V40HL) or by 2 (for the V50HL), and the next refresh address is generated.

In a refresh cycle, a low-level signal is output on the low address pins (A16 to A19).

This refresh address is not affected by a reset. When the device is powered on, the refresh address is undefined.

9. TCU (TIMER/COUNTER UNIT)

The TCU incorporates 3 counters, and can be used as a timer, event counter, rate generator, etc. Functionally it is a subset of the μPD71054.

9.1 FEATURES

- 3 × 16-bit counters
- Six programmable count modes
- Binary/BCD count
- Multiple latch command
- Choice of two input clocks: internal/external

9.2 TCU INTERNAL BLOCK DIAGRAM

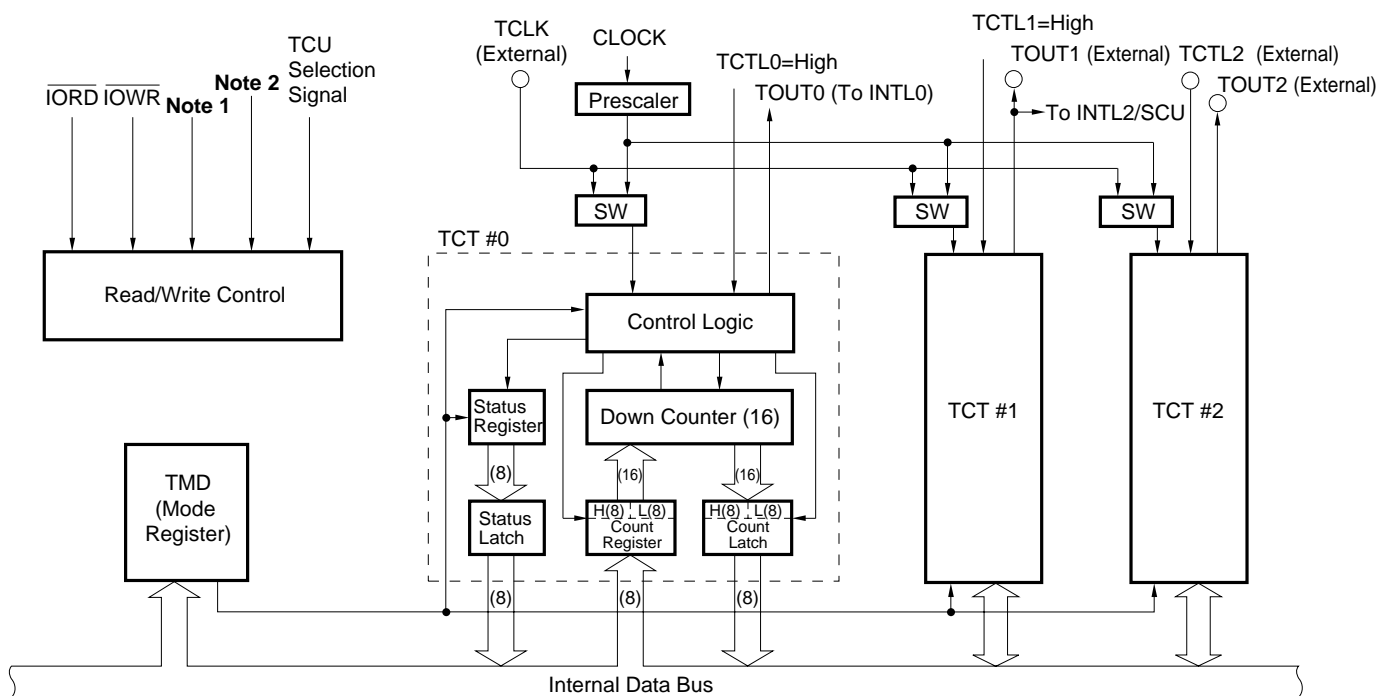

- Notes**
1. A0 or A1 (Set by a system I/O area register)
 2. A1 or A2 (Set by a system I/O area register)

10. SCU (SERIAL CONTROL UNIT)

The SCU performs control of serial communication (asynchronous). Its functions are a subset of the μPD71051 excluding synchronous communication. Also, what was the control word register in the μPD71051 has been divided into two: a command register and a mode register.

10.1 FEATURES

- Dedicated baud rate generator incorporated (using internal clock)
- Asynchronous serial communication
- Clock rate: baud rate × 16, × 64
- Baud rate: DC – 500 kbps
- Character length: 7/8 bits
- Transmit stop bits: 1/2 bits
- Break transmission
- Automatic break detection
- Full-duplex double-buffer system
- Parity addition/checking
- Error detection: parity, overrun, framing
- Interrupt generation maskable

10.2 SCU INTERNAL BLOCK DIAGRAM

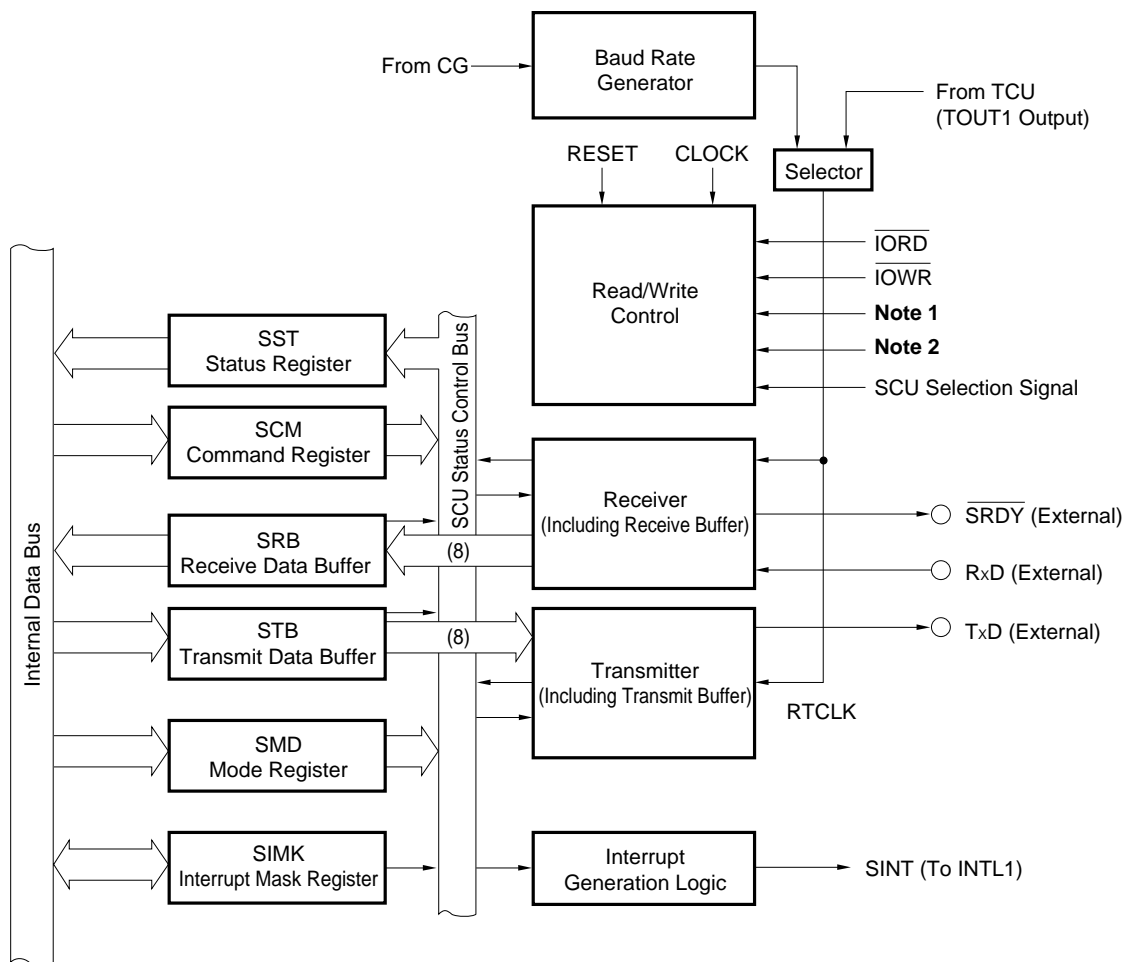

- Notes**
1. A0 or A1 (Set by a system I/O area register)
 2. A1 or A2 (Set by a system I/O area register)

11. ICU (INTERRUPT CONTROL UNIT)

The ICU arbitrates among up to 8 interrupt requests (maskable interrupts) generated inside and outside the V40HL and V50HL, and transfers one of them to the CPU. The ICU functions comprise the functions of the V40HL and V50HL minus those functions not required by the V40HL and V50HL.

11.1 FEATURES

- 8 interrupt inputs
- μPD71059 cascading possible
- Edge- or level-triggered request input
(input from internally connected TCU is edge-triggered only)
- Interrupt requests individually maskable
- Programmable interrupt request priority order
- Polling operation capability

11.2 ICU INTERNAL BLOCK DIAGRAM

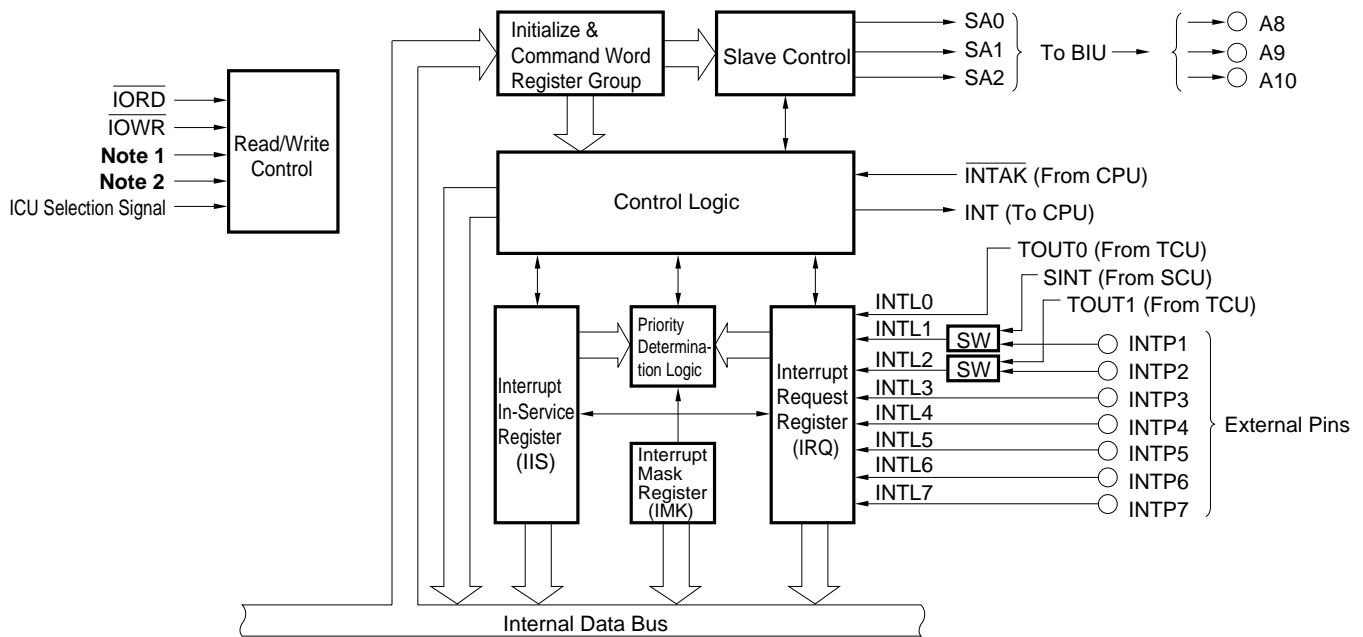

- Notes**
1. A0 or A1 (Set by a system I/O area register)
 2. A1 or A2 (Set by a system I/O area register)

12. DMAU (DMA CONTROL UNIT)

The DMAU has 4 DMA channels, and provides the functions (subset) of two LSIs, the μPD71071 and μPD71037.

12.1 FEATURES

- Two operating modes (μPD71071 mode, μPD71037 mode)
- 20-bit address register
- 16-bit count register
- Four independent DMA channels
- Byte transfer/word transfer selectable
- Three transfer modes (settable on an individual channel basis)
 - Single transfer mode, demand transfer mode, block transfer mode
- Two bus modes (common to all channels: in μPD71037 mode, bus release mode only)
 - Bus release mode
 - Bus hold mode
- DMA requests maskable on an individual channel basis
- Auto initialization function
- Transfer address increment/decrement
- Two channel priority systems (fixed priority/rotating priority)
- \overline{TC} output at end of transfer
- Forced termination of service by \overline{END} input
- Cascading capability

12.2 DMAU INTERNAL BLOCK DIAGRAM

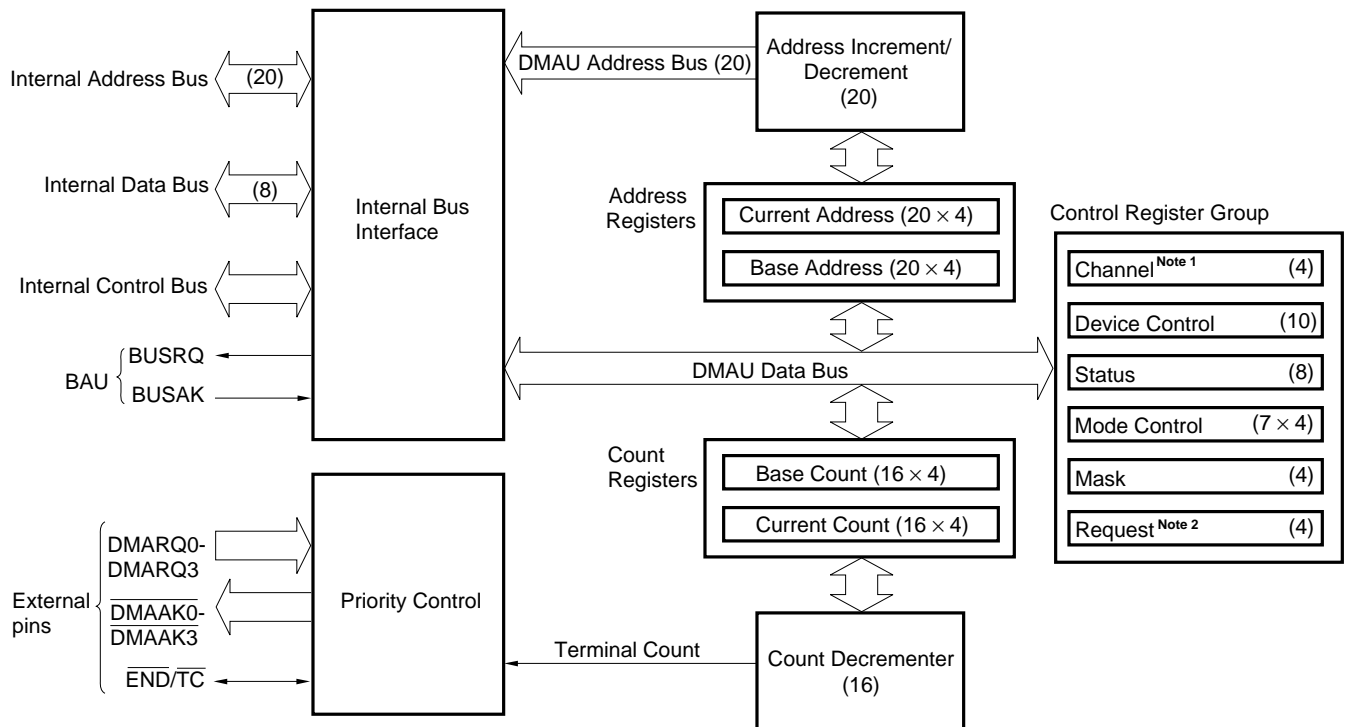

Notes 1. In μPD71071 mode
 2. In μPD71037 mode

13. STANDBY FUNCTIONS

The V40HL and V50HL have two modes, the HALT mode and STOP mode, as standby functions.

(1) HALT mode

When the HALT instruction is executed, the clock to internal CPU circuitry (excluding the HALT mode release circuit) is stopped.

(2) STOP mode

When the HALT instruction is executed, all clocks to the CPU and internal I/Os are stopped. STOP mode should be used when a resonator is connected to the X1 and X2 pins.

Remark Switching between HALT mode and STOP mode is performed by setting a system I/O area register.

14. RESET OPERATION

When the $\overline{\text{RESET}}$ pin is driven low and this level is held for 4 clock cycles or more from the fall of the signal, the CPU and on-chip peripheral LSIs are reset.

When the $\overline{\text{RESET}}$ pin subsequently returns to the high level, the CPU begins an instruction prefetch from address FFFF0H.

When the V40HL and V50HL are reset, its status is fully compatible with the V40 and V50.

Extended functions added to those of the V40 and V50 are mapped onto unused V40 and V50 registers and the reserved area.

Table 14-1 shows the main statuses of the on-chip peripheral LSIs when a reset is performed.

Table 14-1. Main Statuses of On-Chip Peripheral LSIs After Reset

WCU	Memory, external I/O, DMA & refresh : 3-wait insertion Upper & lower memory blocks : set to 512 KB
REFU	Refresh cycle : set to 72 clock cycles Refresh enabling/disabling : not affected by reset
SCU	Baud rate : x 64 Character : 7 bits Parity : None Stop bits : 1 bit Break detection : None
DMAU	μPD71071 mode Demand mode Auto initialization disabled Verify transfer, byte transfer Bus release mode DMA enabled

Caution When a reset is performed, the SCU, TCU, ICU and DMAU cannot be used.

15. INSTRUCTION SET

Table 15-1. Operand Type Legend

Identifier	Description
reg	8/16-bit general register (destination register in an instruction using two 8/16-bit general registers)
reg'	Source register in an instruction using two 8/16-bit general registers
reg8	8-bit general register (destination register in an instruction using two 8-bit general registers)
reg8'	Source register in an instruction using two 8-bit general registers
reg16	16-bit general register (destination register in an instruction using two 16-bit general registers)
reg16'	Source register in an instruction using two 16-bit general registers
dmem	8/16-bit memory location
mem	8/16-bit memory location
mem8	8-bit memory location
mem16	16-bit memory location
mem32	32-bit memory location
imm	Constant in range 0 to FFFFH
imm3	Constant in range 0 to 7
imm4	Constant in range 0 to FH
imm8	Constant in range 0 to FFH
imm16	Constant in range 0 to FFFFH
acc	Accumulator AW or AL
sreg	Segment register
src-table	Name of 256-byte conversion translation table
src-block	Name of block addressed by register IX
dst-block	Name of block addressed by register IY
near-proc	Procedure in current program segment
far-proc	Procedure in a different program segment
near-label	Label in current program segment
short-label	Label in range -128 to +127 bytes from end of instruction
far-label	Label in a different program segment
memptr16	Word containing location offset in a different program segment to which control is to be shifted and segment base address
memptr32	Doubleword containing location offset in a different program segment to which control is to be shifted and segment base address
regptr16	General register containing location offset in a different program segment to which control is to be shifted
pop-value	Number of bytes to be removed from stack (0 to 64K, normally an even number)
fp-op	Immediate value which identifies external floating-point operation coprocessor operation code
R	Register set

Table 15-2. Operation Code Legend

Identifier	Description
W	Byte/word specification bit (0: byte, 1: word). However, when s =1, byte data of sign extension is 16-bit operand if W = 1.
reg	Register field (000 to 111)
reg'	Register field (000 to 111) (source register in instruction which uses two registers)
mem	Memory field (000 to 111)
mod	Mode field (00 to 10)
s	Sign-extended specification bit (0: without sign extension, 1: with sign extension)
X, XXX, YYY, ZZZ	Data used to determine external floating-point coprocessor operation code

Table 15-3. Operand Description Legend

Identifier	Description
AW	Accumulator (16-bit)
AH	Accumulator (high-order byte)
AL	Accumulator (low-order byte)
BW	Register BW (16-bit)
CW	Register CW (16-bit)
CL	Register CL (low-order byte)
DW	Register DW (16-bit)
BP	Base pointer (16-bit)
SP	Stack pointer (16-bit)
PC	Program counter (16-bit)
PSW	Program status word (16-bit)
IX	Index register (source) (16-bit)
IY	Index register (destination) (16-bit)
PS	Program segment register (16-bit)
SS	Stack segment register (16-bit)
DS0	Data segment 0 register (16-bit)
DS1	Data segment 1 register (16-bit)
AC	Auxiliary carry flag
CY	Carry flag
P	Parity flag
S	Sign flag
Z	Zero flag
DIR	Direction flag
IE	Interrupt enable flag
V	Overflow flag
BRK	Break flag
MD	Mode flag
(...)	Contents of memory indicated by contents of ()
disp	Displacement (8/16-bit)
ext-disp8	16 bits with 8-bit displacement sign-extended
temp	Temporary register (8/16/32-bit)
TA	Temporary register A (16-bit)
TB	Temporary register B (16-bit)
TC	Temporary register C (16-bit)
tmpcy	Temporary carry flag (1-bit)
seg	Immediate segment data (16-bit)
offset	Immediate offset data (16-bit)
←	Transfer direction
+	Addition
-	Subtraction
×	Multiplication
÷	Division
%	Modulo
^	Logical product
∨	Logical sum
⊕	Exclusive logical sum
xxH	Two-digit hexadecimal number
xxxxH	Four-digit hexadecimal number

Table 15-4. Flag Operation Legend

Identifier	Description
(Blank)	No change
0	Cleared to 0
1	Set to 1
×	Set or cleared depending upon result
U	Undefined
R	Previously saved value is restored

Table 15-5. Memory Addressing

mod mem	00	01	10
000	BW + IX	BW + IX + disp 8	BW + IX + disp 16
001	BW + IY	BW + IY + disp 8	BW + IY + disp 16
010	BP + IX	BP + IX + disp 8	BP + IX + disp 16
011	BP + IY	BP + IY + disp 8	BP + IY + disp 16
100	IX	IX + disp 8	IX + disp 16
101	IY	IY + disp 8	IY + disp 16
110	DIRECT ADDRESS	BP + disp 8	BP + disp 16
111	BW	BW + disp 8	BW + disp 16

Table 15-6. 8/16-Bit General Register Selection

reg, reg'	W=0	W=1
000	AL	AW
001	CL	CW
010	DL	DW
011	BL	BW
100	AH	SP
101	CH	BP
110	DH	IX
111	BH	IY

Table 15-7. Segment Register Selection

sreg	
00	DS1
01	PS
10	SS
11	DS0

The instruction set is shown in tabular form on the following pages.

Clock cycle shown in table is the time required for execution of instruction by the execution unit and is based on the following conditions.

- Prefetch time and wait time for using bus, etc. are not included.
- 0 wait is assumed for memory access. That is, the clock number of one bus cycle is four clock cycle.
- 0 wait is assumed for I/O access.
- Primitive block transfer instruction and primitive input/output instruction is included repeat prefixes.

The number of clock cycle of instruction with byte processing and word processing (with W bit) is shown as the followings.

(1) V40HL

On the left of "/" : The value corresponding to byte processing (W= 0) or word processing (W = 1) of even address

On the right of "/": The value corresponding to word processing (W =1) of odd address

For the clock of block transfer related instruction of V40HL, see **Table 15-8**.

Table 15-8. Number of Clock Cycles in Block Transfer Related Instruction (V40HL)

Instruction	Number of Clock Cycles	
	Byte Processing (W = 0)	Word Processing (W = 1)
MOVBK	9 + 8 × rep (9)	9 + 16 × rep (17)
CMPBK	7 + 14 × rep (13)	7 + 22 × rep (21)
CMPM	7 + 10 × rep (7)	7 + 14 × rep (11)
LDM	7 + 9 × rep (7)	7 + 13 × rep (11)
STM	5 + 4 × rep (5)	5 + 8 × rep (9)
INM	9 + 8 × rep (10)	9 + 16 × rep (18)
OUTM	9 + 8 × rep (10)	9 + 16 × rep (18)

Remark The figures in parentheses apply to one-time processing only.

(2) V50HL

On the left of "/" : The value corresponding to byte processing (W= 0) or word processing (W = 1) of even address

On the right of "/" : The value corresponding to word processing (W =1) of odd address

For the clock of block transfer related instruction of V50HL, see **Table 15-9**.

Table 15-9. Number of Clock Cycles in Block Transfer Related Instruction V50HL (1/2)

Instruction	Number of Clock Cycles			
	Byte Processing (W = 0)	Word Processing (W = 1)		
		Odd/Odd Address	Odd/Even Address	Even/Even Address
MOVBK	9 + 8 × rep (9)	9 + 16 × rep (17)	9 + 12 × rep (13)	9 + 8 × rep (9)
CMPBK	7 + 14 × rep (13)	7 + 22 × rep (21)	7 + 18 × rep (17)	7 + 14 × rep (13)
INM	9 + 8 × rep (10)	9 + 16 × rep (18)	9 + 12 × rep (14)	9 + 8 × rep (10)
OUTM	9 + 8 × rep (10)	9 + 16 × rep (18)	9 + 12 × rep (14)	9 + 8 × rep (10)

Remark The figures in parentheses apply to one-time processing only.

Table 15-9. Number of Clock Cycles in Block Transfer Related Instruction (V50HL) (2/2)

Instruction	Number of Clock Cycles		
	Byte Processing (W = 0)	Word Processing (W = 1)	
		Odd Address	Even Address
CMPM	7 + 10 × rep (7)	7 + 14 × rep (11)	7 + 10 × rep (7)
LDM	7 + 9 × rep (7)	7 + 13 × rep (11)	7 + 9 × rep (7)
STM	5 + 4 × rep (5)	5 + 8 × rep (9)	5 + 4 × rep (5)

Remark The figures in parentheses apply to one-time processing only.



Instruc- tion Group	Mnemonic	Operand(s)	Operation Code		Bytes	Clock Cycles		Operation	Flags						
			7 6 5 4 3 2 1 0	7 6 5 4 3 2 1 0		V40HL	V50HL		AC	CY	V	P	S	Z	
			Data transfer instructions	MOV		reg, reg'	1 0 0 0 1 0 1 W		1 1 reg reg'	2	2	2	reg ← reg'		
mem, reg	1 0 0 0 1 0 0 W	mod reg mem			2-4	7/11	7/11	(mem) ← reg							
reg, mem	1 0 0 0 1 0 1 W	mod reg mem			2-4	10/14	10/14	reg ← (mem)							
mem, imm	1 1 0 0 0 1 1 W	mod 0 0 0 mem			3-6	9/13	9/13	(mem) ← imm							
reg, imm	1 0 1 1 W reg				2-3	4	4	reg ← imm							
acc, dmem	1 0 1 0 0 0 0 W				3	10/14	10/14	If W=0: AL ← (dmem) If W=1: AH ← (dmem + 1), AL ← (dmem)							
dmem, acc	1 0 1 0 0 0 1 W				3	9/13	9/13	If W=0: (dmem) ← AL If W=1: (dmem + 1) ← AH, (dmem) ← AL							
sreg, reg16	1 0 0 0 1 1 1 0	1 1 0 sreg reg			2	2	2	sreg ← reg16	sreg:SS, DS0, DS1						
sreg, mem16	1 0 0 0 1 1 1 0	mod 0 sreg mem			2-4	14	10/14	sreg ← (mem16)	sreg:SS, DS0, DS1						
reg16, sreg	1 0 0 0 1 1 0 0	1 1 0 sreg reg			2	2	2	reg16 ← sreg							
mem16, sreg	1 0 0 0 1 1 0 0	mod 0 sreg mem			2-4	12	8/12	(mem16) ← sreg							
DS0, reg16, mem32	1 1 0 0 0 1 0 1	mod reg mem			2-4	25	17/25	reg16 ← (mem32) DS0 ← (mem32 + 2)							
DS1, reg16, mem32	1 1 0 0 0 1 0 0	mod reg mem			2-4	25	17/25	reg16 ← (mem32) DS1 ← (mem32 + 2)							
AH, PSW	1 0 0 1 1 1 1 1				1	2	2	AH ← S, Z, ×, AC, ×, P, ×, CY							
PSW, AH	1 0 0 1 1 1 1 0			1	3	3	S, Z, ×, AC, ×, P, ×, CY ← AH	×	×		×	×	×		
LDEA	reg16, mem16	1 0 0 0 1 1 0 1		mod reg mem	2-4	4	4	reg16 ← mem16							
TRANS	src-table	1 1 0 1 0 1 1 1			1	9	9	AL ← (BW + AL)							
XCH	reg, reg'	1 0 0 0 0 1 1 W		1 1 reg reg'	2	3	3	reg ↔ reg'							
	mem, reg reg, mem	1 0 0 0 0 1 1 W		mod reg mem	2-4	13/21	13/21	(mem) ↔ reg							
	AW, reg16 reg16, AW	1 0 0 1 0 reg			1	3	3	AW ↔ reg16							

Instruction Group	Mnemonic	Operand(s)	Operation Code		Bytes	Clock Cycles		Operation	Flags							
			7 6 5 4 3 2 1 0	7 6 5 4 3 2 1 0		V40HL	V50HL		AC	CY	V	P	S	Z		
			Repeat prefixes													
	REPC		0 1 1 0 0 1 0 1		1	2	2	While CW ≠ 0, the following byte primitive block transfer instruction is executed and CW is decremented (−1). If there is a pending interrupt, it is serviced. If CY ≠ 1 the loop is exited.								
	REPNC		0 1 1 0 0 1 0 0		1	2	2	Same as above If CY ≠ 0 the loop is exited.								
	REP		1 1 1 1 0 0 1 1		1	2	2	While CW ≠ 0, the following byte primitive block transfer instruction is executed and CW is decremented (−1). If there is a pending interrupt, it is serviced. If the primitive block transfer instruction is CMPBK or CPM and Z ≠ 1 the loop is exited.								
	REPE															
	REPZ															
	REPNE		1 1 1 1 0 0 1 0		1	2	2	Same as above If Z ≠ 0 the loop is exited.								
	REPZ															
Primitive block transfer instructions																
	MOVBK	dst-block, src-block	1 0 1 0 0 1 0 W		1	See Table 15-8	See Table 15-9	If W = 0: (IY) ← (IX) DIR = 0 : IX ← IX + 1, IY ← IY + 1 DIR = 1 : IX ← IX − 1, IY ← IY − 1 If W = 1: (IY + 1, IY) ← (IX + 1, IX) DIR = 0 : IX ← IX + 2, IY ← IY + 2 DIR = 1 : IX ← IX − 2, IY ← IY − 2								
	CMPBK	src-block, dst-block	1 0 1 0 0 1 1 W		1	See Table 15-8	See Table 15-9	If W = 0: (IX) − (IY) DIR = 0 : IX ← IX + 1, IY ← IY + 1 DIR = 1 : IX ← IX − 1, IY ← IY − 1 If W = 1: (IX + 1, IX) − (IY + 1, IY) DIR = 0 : IX ← IX + 2, IY ← IY + 2 DIR = 1 : IX ← IX − 2, IY ← IY − 2	×	×	×	×	×	×		
	CMPM	dst-block	1 0 1 0 1 1 1 W		1	See Table 15-8	See Table 15-9	If W = 0: AL − (IY) DIR = 0 : IY ← IY + 1; DIR = 1 : IY ← IY − 1 If W = 1: AW − (IY + 1, IY) DIR = 0 : IY ← IY + 2; DIR = 1 : IY ← IY − 2	×	×	×	×	×	×		
	LDM	src-block	1 0 1 0 1 1 0 W		1	See Table 15-8	See Table 15-9	If W = 0: AL ← (IX) DIR = 0 : IX ← IX + 1; DIR = 1 : IX ← IX − 1 If W = 1: AW ← (IX + 1, IX) DIR = 0 : IX + 2; DIR = 1 : IX ← IX − 2								
	STM	dst-block	1 0 1 0 1 0 1 W		1	See Table 15-8	See Table 15-9	If W = 0: (IY) ← AL DIR = 0 : IY ← IY + 1; DIR = 1 : IY ← IY − 1 If W = 1: (IY + 1, IY) ← AW DIR = 0 : IY ← IY + 2; DIR = 1 : IY ← IY − 2								

Instruction Group	Mnemonic	Operand(s)	Operation Code		Bytes	Clock Cycles		Operation	Flags						
			7 6 5 4 3 2 1 0	7 6 5 4 3 2 1 0		V40HL	V50HL		AC	CY	V	P	S	Z	
Bit field manipulation instructions	INS	reg8, reg8'	0 0 0 0 1 1 1 1	0 0 1 1 0 0 0 1	3	35-133	31-117/	16-bit field ← AW							
		1 1 reg' reg		35-133											
	reg8, imm4	0 0 0 0 1 1 1 1	0 0 1 1 1 0 0 1	4	35-133	31-117/	16-bit field ← AW								
		1 1 0 0 0 reg				35-133									
	EXT	reg8, reg8'	0 0 0 0 1 1 1 1	0 0 1 1 0 0 1 1	3	34-59	26-55/	AW ← 16-bit field							
		1 1 reg' reg		34-59											
reg8, imm4	0 0 0 0 1 1 1 1	0 0 1 1 1 0 1 1	4	34-59	26-55/	AW ← 16-bit field									
	1 1 0 0 0 reg				34-59										
Input/output instructions	IN	acc, imm8	1 1 1 0 0 1 0 W		2	9/13	9/13 ^{Note}	If W = 0: AL ← (imm8) If W = 1: AH ← (imm8 + 1), AL ← (imm8)							
		acc, DW	1 1 1 0 1 1 0 W			8/12	8/12 ^{Note}		If W = 0: AL ← (DW) If W = 1: AH ← (DW + 1), AL ← (DW)						
	OUT	imm8, acc	1 1 1 0 0 1 1 W		2	8/12	8/12 ^{Note}	If W = 0: (imm8) ← AL If W = 1: (imm8 + 1) ← AH, (imm8) ← AL							
		DW, acc	1 1 1 0 1 1 1 W			8/12	8/12 ^{Note}		If W = 0: (DW) ← AL If W = 1: (DW + 1) ← AH, (DW) ← AL						
Primitive input/output instructions	INM	dst-block, DW	0 1 1 0 1 1 0 W		1	See Table 15-8	See Table 15-9	If W = 0: (IY) ← (DW) DIR = 0 : IY ← IY + 1 ; DIR = 1 : IY ← IY - 1 If W = 1: (IY + 1, IY) ← (DW + 1, DW) DIR = 0 : IY ← IY + 2 ; DIR = 1 : IY ← IY - 2							
	OUTM	DW, src-block	0 1 1 0 1 1 1 W						1	See Table 15-8	See Table 15-9	If W = 0: (DW) ← (IX) DIR = 0 : IX ← IX + 1 ; DIR = 1 : IX ← IX - 1 If W = 1: (DW + 1, DW) ← (IX + 1, IX) DIR = 0 : IX ← IX + 2 ; DIR = 1 : IX ← IX - 2			

Note In case of IN/OUT instruction to internal DMAU, the number of word processing clock cycles applied is always that to the right of "/".

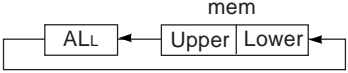
Instruc- tion Group	Mnemonic	Operand(s)	Operation Code		Bytes	Clock Cycles		Operation	Flags					
			7 6 5 4 3 2 1 0	7 6 5 4 3 2 1 0		V40HL	V50HL		AC	CY	V	P	S	Z
			Addition/subtraction instructions	ADD		reg, reg'	0 0 0 0 0 0 1 W		1 1 reg reg'	2	2	2	reg ← reg + reg'	x
mem, reg	0 0 0 0 0 0 0 W	mod reg mem			2-4	13/21	13/21	(mem) ← (mem) + reg	x	x	x	x	x	x
reg, mem	0 0 0 0 0 0 1 W	mod reg mem			2-4	10/14	10/14	reg ← reg + (mem)	x	x	x	x	x	x
reg, imm	1 0 0 0 0 0 s W	1 1 0 0 0 reg			3-4	4	4	reg ← reg + imm	x	x	x	x	x	x
mem, imm	1 0 0 0 0 0 s W	mod 0 0 0 mem			3-6	15/23	15/23	(mem) ← (mem) + imm	x	x	x	x	x	x
acc, imm	0 0 0 0 0 1 0 W				2-3	4	4	If W = 0: AL ← AL + imm If W = 1: AW ← AW + imm	x	x	x	x	x	x
ADDC	reg, reg'	0 0 0 1 0 0 1 W		1 1 reg reg'	2	2	2	reg ← reg + reg' + CY	x	x	x	x	x	x
	mem, reg	0 0 0 1 0 0 0 W		mod reg mem	2-4	13/21	13/21	(mem) ← (mem) + reg + CY	x	x	x	x	x	x
	reg, mem	0 0 0 1 0 0 1 W		mod reg mem	2-4	10/14	10/14	reg ← reg + (mem) + CY	x	x	x	x	x	x
	reg, imm	1 0 0 0 0 0 s W		1 1 0 1 0 reg	3-4	4	4	reg ← reg + imm + CY	x	x	x	x	x	x
	mem, imm	1 0 0 0 0 0 s W		mod 0 1 0 mem	3-6	15/23	15/23	(mem) ← (mem) + imm + CY	x	x	x	x	x	x
	acc, imm	0 0 0 1 0 1 0 W			2-3	4	4	If W = 0: AL ← AL + imm + CY If W = 1: AW ← AW + imm + CY	x	x	x	x	x	x
SUB	reg, reg'	0 0 1 0 1 0 1 W		1 1 reg reg'	2	2	2	reg ← reg - reg'	x	x	x	x	x	x
	mem, reg	0 0 1 0 1 0 0 W		mod reg mem	2-4	13/21	13/21	(mem) ← (mem) - reg	x	x	x	x	x	x
	reg, mem	0 0 1 0 1 0 1 W		mod reg mem	2-4	10/14	10/14	reg ← reg - (mem)	x	x	x	x	x	x
	reg, imm	1 0 0 0 0 0 s W		1 1 1 0 1 reg	3-4	4	4	reg ← reg - imm	x	x	x	x	x	x
	mem, imm	1 0 0 0 0 0 s W		mod 1 0 1 mem	3-6	15/23	15/23	(mem) ← (mem) - imm	x	x	x	x	x	x
	acc, imm	0 0 1 0 1 1 0 W			2-3	4	4	If W = 0: AL ← AL - imm If W = 1: AW ← AW - imm	x	x	x	x	x	x
SUBC	reg, reg'	0 0 0 1 1 0 1 W		1 1 reg reg'	2	2	2	reg ← reg - reg' - CY	x	x	x	x	x	x
	mem, reg	0 0 0 1 1 0 0 W		mod reg mem	2-4	13/21	13/21	(mem) ← (mem) - reg - CY	x	x	x	x	x	x
	reg, mem	0 0 0 1 1 0 1 W		mod reg mem	2-4	10/14	10/14	reg ← reg - (mem) - CY	x	x	x	x	x	x
	reg, imm	1 0 0 0 0 0 s W		1 1 0 1 1 reg	3-4	4	4	reg ← reg - imm - CY	x	x	x	x	x	x
	mem, imm	1 0 0 0 0 0 s W		mod 0 1 1 mem	3-6	15/23	15/23	(mem) ← (mem) - imm - CY	x	x	x	x	x	x
	acc, imm	0 0 0 1 1 1 0 W			2-3	4	4	If W = 0: AL ← AL - imm - CY If W = 1: AW ← AW - imm - CY	x	x	x	x	x	x

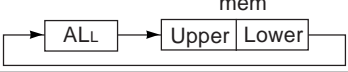
Instruction Group	Mnemonic	Operand(s)	Operation Code		Bytes	Clock Cycles		Operation	Flags						
			7 6 5 4 3 2 1 0	7 6 5 4 3 2 1 0		V40HL	V50HL		AC	CY	V	P	S	Z	
BCD operation instructions	ADD4S		0 0 0 0 1 1 1 1	0 0 1 0 0 0 0 0	2	19 × n + 7	19 × n + 7	dst BCD string ← dst BCD string + src BCD string*	U	×	U	U	U	×	
	SUB4S		0 0 0 0 1 1 1 1	0 0 1 0 0 0 1 0	2	19 × n + 7	19 × n + 7	dst BCD string ← dst BCD string – src BCD string*	U	×	U	U	U	×	
	CMP4S		0 0 0 0 1 1 1 1	0 0 1 0 0 1 1 0	2	19 × n + 7	19 × n + 7	dst BCD string – src BCD string*	U	×	U	U	U	×	
	ROL4	reg8		0 0 0 0 1 1 1 1 1 1 0 0 0 reg	0 0 1 0 1 0 0 0	3	13	13							
		mem8		0 0 0 0 1 1 1 1 mod 0 0 0 mem	0 0 1 0 1 0 0 0	3-5	25	25							
	ROR4	reg8		0 0 0 0 1 1 1 1 1 1 0 0 0 reg	0 0 1 0 1 0 1 0	3	17	17							
mem8			0 0 0 0 1 1 1 1 mod 0 0 0 mem	0 0 1 0 1 0 1 0	3-5	29	29								
Increment/decrement instructions	INC	reg8	1 1 1 1 1 1 1 0	1 1 0 0 0 reg	2	2	2	reg8 ← reg8 + 1	×		×	×	×	×	
		mem	1 1 1 1 1 1 1 W	mod 0 0 0 mem	2-4	13/21	13/21	(mem) ← (mem) + 1	×		×	×	×	×	
		reg16	0 1 0 0 0 reg		1	2	2	reg16 ← reg16 + 1	×		×	×	×	×	
	DEC	reg8	1 1 1 1 1 1 1 0	1 1 0 0 1 reg	2	2	2	reg8 ← reg8 – 1	×		×	×	×	×	
		mem	1 1 1 1 1 1 1 W	mod 0 0 1 mem	2-4	13/21	13/21	(mem) ← (mem) – 1	×		×	×	×	×	
		reg16	0 1 0 0 1 reg		1	2	2	reg16 ← reg16 – 1	×		×	×	×	×	

n: 1/2 the number of BCD digits

* The number of BCD digits is given by the CL register: a value between 1 and 254 can be set.

Instruction Group	Mnemonic	Operand(s)	Operation Code		Bytes	Clock Cycles		Operation	Flags					
			7 6 5 4 3 2 1 0	7 6 5 4 3 2 1 0		V40HL	V50HL		AC	CY	V	P	S	Z
Multiplication instructions	MULU	reg8	1 1 1 1 0 1 1 0	1 1 1 0 0 reg	2	21-22	21-22	AW ← AL × reg8 AH = 0: CY ← 0, V ← 0 AH ≠ 0: CY ← 1, V ← 1	U	×	×	U	U	U
		mem8	1 1 1 1 0 1 1 0	mod 1 0 0 mem	2-4	26-27	26-27	AW ← AL × (mem8) AH = 0: CY ← 0, V ← 0 AH ≠ 0: CY ← 1, V ← 1	U	×	×	U	U	U
		reg16	1 1 1 1 0 1 1 1	1 1 1 0 0 reg	2	29-30	29-30	DW, AW ← AW × reg16 DW = 0: CY ← 0, V ← 0 DW ≠ 0: CY ← 1, V ← 1	U	×	×	U	U	U
		mem16	1 1 1 1 0 1 1 1	mod 1 0 0 mem	2-4	38-39	34-35/ 38-39	DW, AW ← AW × (mem16) DW = 0: CY ← 0, V ← 0 DW ≠ 0: CY ← 1, V ← 1	U	×	×	U	U	U
	MUL	reg8	1 1 1 1 0 1 1 0	1 1 1 0 1 reg	2	33-39	33-39	AW ← AL × reg8 AH = AL sign extension: CY ← 0, V ← 0 AH ≠ AL sign extension: CY ← 1, V ← 1	U	×	×	U	U	U
		mem8	1 1 1 1 0 1 1 0	mod 1 0 1 mem	2-4	38-44	38-44	AW ← AL × (mem8) AH = AL sign extension: CY ← 0, V ← 0 AH ≠ AL sign extension: CY ← 1, V ← 1	U	×	×	U	U	U
		reg16	1 1 1 1 0 1 1 1	1 1 1 0 1 reg	2	41-47	41-47	DW, AW ← AW × reg16 DW = AW sign extension: CY ← 0, V ← 0 DW ≠ AW sign extension: CY ← 1, V ← 1	U	×	×	U	U	U
		mem16	1 1 1 1 0 1 1 1	mod 1 0 1 mem	2-4	50-56	46-52/ 50-56	DW, AW ← AW × (mem16) DW = AW sign extension: CY ← 0, V ← 0 DW ≠ AW sign extension: CY ← 1, V ← 1	U	×	×	U	U	U
		reg16, (reg16'), ^{Note} imm8	0 1 1 0 1 0 1 1	1 1 reg reg'	3	28-34	28-34	reg16 ← reg16' × imm8 Product ≤ 16 bits : CY ← 0, V ← 0 Product > 16 bits : CY ← 1, V ← 1	U	×	×	U	U	U
		reg16, mem16, imm8	0 1 1 0 1 0 1 1	mod reg mem	3-5	37-43	33-39/ 37-43	reg16 ← (mem16) × imm8 Product ≤ 16 bits : CY ← 0, V ← 0 Product > 16 bits : CY ← 1, V ← 1	U	×	×	U	U	U
		reg16, (reg16'), ^{Note} imm16	0 1 1 0 1 0 0 1	1 1 reg reg'	4	36-42	36-42	reg16 ← reg16' × imm16 Product ≤ 16 bits : CY ← 0, V ← 0 Product > 16 bits : CY ← 1, V ← 1	U	×	×	U	U	U
		reg16, mem16, imm16	0 1 1 0 1 0 0 1	mod reg mem	4-6	45-51	41-47/ 45-51	reg16 ← (mem16) × imm16 Product ≤ 16 bits : CY ← 0, V ← 0 Product > 16 bits : CY ← 1, V ← 1	U	×	×	U	U	U

Note The 2nd operand can be omitted, in which case the same register as the 1st operand is taken as being specified.

Instruc- tion Group	Mnemonic	Operand(s)	Operation Code		Bytes	Clock Cycles		Operation	Flags					
			7 6 5 4 3 2 1 0	7 6 5 4 3 2 1 0		V40HL	V50HL		AC	CY	V	P	S	Z
			Unsigned division instructions											
	DIVU	reg8	1 1 1 1 0 1 1 0	1 1 1 1 0 reg	2	19	19	temp ← AW If temp ÷ reg8 ≤ FFH AH ← temp%reg8, AL ← temp ÷ reg8 If temp ÷ reg8 > FFH TA ← (001H, 000H), TC ← (003H, 002H) SP ← SP - 2, (SP + 1, SP) ← PSW, IE ← 0, BRK ← 0 SP ← SP - 2, (SP + 1, SP) ← PS, PS ← TC SP ← SP - 2, (SP + 1, SP) ← PC, PC ← TA	U	U	U	U	U	U
		mem8	1 1 1 1 0 1 1 0	mod 1 1 0 mem	2-4	24	24	temp ← AW If temp ÷ (mem8) ≤ FFH AH ← temp%(mem8), AL ← temp ÷ (mem8) If temp ÷ (mem8) > FFH TA ← (001H, 000H), TC ← (003H, 002H) SP ← SP - 2, (SP + 1, SP) ← PSW, IE ← 0, BRK ← 0 SP ← SP - 2, (SP + 1, SP) ← PS, PS ← TC SP ← SP - 2, (SP + 1, SP) ← PC, PC ← TA	U	U	U	U	U	U
		reg16	1 1 1 1 0 1 1 1	1 1 1 1 0 reg	2	25	25	temp ← DW, AW If temp ÷ reg16 ≤ FFFFH DW ← temp%reg16, AW ← temp ÷ reg16 If temp ÷ reg16 > FFFFH TA ← (001H, 000H), TC ← (003H, 002H) SP ← SP - 2, (SP + 1, SP) ← PSW, IE ← 0, BRK ← 0 SP ← SP - 2, (SP + 1, SP) ← PS, PS ← TC SP ← SP - 2, (SP + 1, SP) ← PC, PC ← TA	U	U	U	U	U	U
		mem16	1 1 1 1 0 1 1 1	mod 1 1 0 mem	2-4	34	30/34	temp ← DW, AW If temp ÷ (mem16) ≤ FFFFH DW ← temp%(mem16), AW ← temp ÷ (mem16) If temp ÷ (mem16) > FFFFH TA ← (001H, 000H), TC ← (003H, 002H) SP ← SP - 2, (SP + 1, SP) ← PSW, IE ← 0, BRK ← 0 SP ← SP - 2, (SP + 1, SP) ← PS, PS ← TC SP ← SP - 2, (SP + 1, SP) ← PC, PC ← TA	U	U	U	U	U	U

Instruc- tion Group	Mnemonic	Operand(s)	Operation Code		Bytes	Clock Cycles		Operation	Flags					
			7 6 5 4 3 2 1 0	7 6 5 4 3 2 1 0		V40HL	V50HL		AC	CY	V	P	S	Z
			Signed division instructions	DIV		reg8	1 1 1 1 0 1 1 0		1 1 1 1 1 reg	2	29-34	29-34	temp ← AW If temp ÷ reg8 > 0 and temp ÷ reg8 ≤ 7FH or temp ÷ reg8 < 0 and temp ÷ reg8 > 0 – 7FH –1 AH ← temp%reg8, AL ← temp ÷ reg8 If temp ÷ reg8 > 0 and temp ÷ reg8 > 7FH or temp ÷ reg8 < 0 and temp ÷ reg8 ≤ 0 – 7FH –1 TA ← (001H, 000H), TC ← (003H, 002H) SP ← SP – 2, (SP + 1, SP) ← PSW, IE ← 0, BRK ← 0 SP ← SP – 2, (SP + 1, SP) ← PS, PS ← TC SP ← SP – 2, (SP + 1, SP) ← PC, PC ← TA	U
	mem8	1 1 1 1 0 1 1 0		mod 1 1 1 mem	2-4	34-39	34-39	temp ← AW If temp ÷ (mem8) > 0 and temp ÷ (mem8) ≤ 7FH or temp ÷ (mem8) < 0 and temp ÷ (mem8) > 0 – 7FH –1 AH ← temp%(mem8), AL ← temp ÷ (mem8) If temp ÷ (mem8) > 0 and temp ÷ (mem8) > 7FH or temp ÷ (mem8) < 0 and temp ÷ (mem8) ≤ 0 – 7FH –1 TA ← (001H, 000H), TC ← (003H, 002H) SP ← SP – 2, (SP + 1, SP) ← PSW, IE ← 0, BRK ← 0 SP ← SP – 2, (SP + 1, SP) ← PS, PS ← TC SP ← SP – 2, (SP + 1, SP) ← PC, PC ← TA	U	U	U	U	U	U
	reg16	1 1 1 1 0 1 1 1		1 1 1 1 1 reg	2	38-43	38-43	temp ← DW, AW If temp ÷ reg16 > 0 and temp ÷ reg16 ≤ 7FFFH or temp ÷ reg16 < 0 and temp ÷ reg16 > 0 – 7FFFH –1 DW ← temp%reg16, AW ← temp ÷ reg16 If temp ÷ reg16 > 0 and temp ÷ reg16 > 7FFFH or temp ÷ reg16 < 0 and temp ÷ reg16 ≤ 0 – 7FFFH –1 TA ← (001H, 000H), TC ← (003H, 002H) SP ← SP – 2, (SP + 1, SP) ← PSW, IE ← 0, BRK ← 0 SP ← SP – 2, (SP + 1, SP) ← PS, PS ← TC SP ← SP – 2, (SP + 1, SP) ← PC, PC ← TA	U	U	U	U	U	U
	mem16	1 1 1 1 0 1 1 1		mod 1 1 1 mem	2-4	47-52	43-48/ 47-52	temp ← DW, AW If temp ÷ (mem16) > 0 and temp ÷ (mem16) ≤ 7FFFH or temp ÷ (mem16) < 0 and temp ÷ (mem16) > 0 – 7FFFH –1 DW ← temp%(mem16), AW ← temp ÷ (mem16) If temp ÷ (mem16) > 0 and temp ÷ (mem16) > 7FFFH or temp ÷ (mem16) < 0 and temp ÷ (mem16) ≤ 0 – 7FFFH –1 TA ← (001H, 000H), TC ← (003H, 002H) SP ← SP – 2, (SP + 1, SP) ← PSW, IE ← 0, BRK ← 0	U	U	U	U	U	U

Instruc- tion Group	Mnemonic	Operand(s)	Operation Code		Bytes	Clock Cycles		Operation	Flags						
			7 6 5 4 3 2 1 0	7 6 5 4 3 2 1 0		V40HL	V50HL		AC	CY	V	P	S	Z	
BCD adjustment instructions	ADJBA		0 0 1 1 0 1 1 1		1	7	7	If $AL \wedge 0FH > 9$ or $AC = 1$: $AL \leftarrow AL + 6$ $AH \leftarrow AH + 1, AC \leftarrow 1, CY \leftarrow AC, AL \leftarrow AL \wedge 0FH$	x	x	U	U	U	U	
	ADJ4A		0 0 1 0 0 1 1 1		1	3	3	If $AL \wedge 0FH > 9$ or $AC = 1$ $AL \leftarrow AL + 6, CY \leftarrow CY \vee AC, AC \leftarrow 1$ If $AL > 9FH$ or $CY = 1$ $AL \leftarrow AL + 60H, CY \leftarrow 1$	x	x	U	x	x	x	
	ADJBS		0 0 1 1 1 1 1 1		1	7	7	If $AL \wedge 0FH > 9$ or $AC = 1$ $AL \leftarrow AL - 6, AH \leftarrow AH - 1, AC \leftarrow 1$ $CY \leftarrow AC, AL \leftarrow AL \wedge 0FH$	x	x	U	U	U	U	
	ADJ4S		0 0 1 0 1 1 1 1		1	3	3	If $AL \wedge 0FH > 9$ or $AC = 1$ $AL \leftarrow AL - 6, CY \leftarrow CY \vee AC, AC \leftarrow 1$ If $AL > 9FH$ or $CY = 1$ $AL \leftarrow AL - 60H, CY \leftarrow 1$	x	x	U	x	x	x	
Data conversion instructions	CVTBD		1 1 0 1 0 1 0 0	0 0 0 0 1 0 1 0	2	15	15	$AH \leftarrow AL \div 0AH, AL \leftarrow AL \% 0AH$	U	U	U	x	x	x	
	CVTDB		1 1 0 1 0 1 0 1	0 0 0 0 1 0 1 0	2	7	7	$AL \leftarrow AH \times 0AH + AL, AH \leftarrow 0$	U	U	U	x	x	x	
	CVTBW		1 0 0 1 1 0 0 0		1	2	2	If $AL < 80H$: $AH \leftarrow 0$, otherwise: $AH \leftarrow FFH$							
	CVTWL		1 0 0 1 1 0 0 1		1	4-5	4-5	If $AW < 8000H$: $DW \leftarrow 0$, otherwise: $DW \leftarrow FFFFH$							
Comparison instructions	CMP	reg, reg'	0 0 1 1 1 0 1 W	1 1 reg reg'	2	2	2	$reg - reg'$	x	x	x	x	x	x	
		mem, reg	0 0 1 1 1 0 0 W	mod reg mem	2-4	10/14	10/14	$(mem) - reg$	x	x	x	x	x	x	
		reg, mem	0 0 1 1 1 0 1 W	mod reg mem	2-4	10/14	10/14	$reg - (mem)$	x	x	x	x	x	x	
		reg, imm	1 0 0 0 0 s W	1 1 1 1 1 reg	3-4	4	4	$reg - imm$	x	x	x	x	x	x	
		mem, imm	1 0 0 0 0 s W	mod 1 1 1 mem	3-6	12/16	12/16	$(mem) - imm$	x	x	x	x	x	x	
		acc, imm	0 0 1 1 1 1 0 W		2-3	4	4	If $W = 0$: $AL - imm$ If $W = 1$: $AW - imm$	x	x	x	x	x	x	
Complement operation instructions	NOT	reg	1 1 1 1 0 1 1 W	1 1 0 1 0 reg	2	2	2	$reg \leftarrow \overline{reg}$							
		mem	1 1 1 1 0 1 1 W	mod 0 1 0 mem	2-4	13/21	13/21	$(mem) \leftarrow \overline{(mem)}$							
	NEG	reg	1 1 1 1 0 1 1 W	1 1 0 1 1 reg	2	2	2	$reg \leftarrow \overline{reg} + 1$	x	x	x	x	x	x	
		mem	1 1 1 1 0 1 1 W	mod 0 1 mem	2-4	13/21	13/21	$(mem) \leftarrow \overline{(mem)} + 1$	x	x	x	x	x	x	

Instruc- tion Group	Mnemonic	Operand(s)	Operation Code		Bytes	Clock Cycles		Operation	Flags					
			7 6 5 4 3 2 1 0	7 6 5 4 3 2 1 0		V40HL	V50HL		AC	CY	V	P	S	Z
			Logical operation instructions	TEST		reg, reg'	1 0 0 0 0 1 0 W		1 1 reg' reg	2	2	2	reg \wedge reg'	U
mem, reg reg, mem	1 0 0 0 0 1 0 W	mod reg mem			2-4	9/13	9/13	(mem) \wedge reg	U	0	0	x	x	x
reg, imm	1 1 1 1 0 1 1 W	1 1 0 0 0 reg			3-4	4	4	reg \wedge imm	U	0	0	x	x	x
mem, imm	1 1 1 1 0 1 1 W	mod 0 0 0 mem			3-6	10/14	10/14	(mem) \wedge imm	U	0	0	x	x	x
acc, imm	1 0 1 0 1 0 0 W				2-3	4	4	If W = 0: AL \wedge imm8 If W = 1: AW \wedge imm16	U	0	0	x	x	x
AND	reg, reg'	0 0 1 0 0 0 1 W		1 1 reg reg'	2	2	2	reg \leftarrow reg \wedge reg'	U	0	0	x	x	x
	mem, reg	0 0 1 0 0 0 0 W		mod reg mem	2-4	13/21	13/21	(mem) \leftarrow (mem) \wedge reg	U	0	0	x	x	x
	reg, mem	0 0 1 0 0 0 1 W		mod reg mem	2-4	10/14	10/14	reg \leftarrow reg \wedge (mem)	U	0	0	x	x	x
	reg, imm	1 0 0 0 0 0 0 W		1 1 1 0 0 reg	3-4	4	4	reg \leftarrow reg \wedge imm	U	0	0	x	x	x
	mem, imm	1 0 0 0 0 0 0 W		mod 1 0 0 mem	3-6	15/23	15/23	(mem) \leftarrow (mem) \wedge imm	U	0	0	x	x	x
	acc, imm	0 0 1 0 0 1 0 W			2-3	4	4	If W = 0: AL \leftarrow AL \wedge imm8 If W = 1: AW \leftarrow AW \wedge imm16	U	0	0	x	x	x
OR	reg, reg'	0 0 0 0 1 0 1 W		1 1 reg reg'	2	2	2	reg \leftarrow reg \vee reg'	U	0	0	x	x	x
	mem, reg	0 0 0 0 1 0 0 W		mod reg mem	2-4	13/21	13/21	(mem) \leftarrow (mem) \vee reg	U	0	0	x	x	x
	reg, mem	0 0 0 0 1 0 1 W		mod reg mem	2-4	10/14	10/14	reg \leftarrow reg \vee (mem)	U	0	0	x	x	x
	reg, imm	1 0 0 0 0 0 0 W		1 1 0 0 1 reg	3-4	4	4	reg \leftarrow reg \vee imm	U	0	0	x	x	x
	mem, imm	1 0 0 0 0 0 0 W		mod 0 0 1 mem	3-6	15/23	15/23	(mem) \leftarrow (mem) \vee imm	U	0	0	x	x	x
	acc, imm	0 0 0 0 1 1 0 W			2-3	4	4	If W = 0: AL \leftarrow AL \vee imm8 If W = 1: AW \leftarrow AW \vee imm16	U	0	0	x	x	x
XOR	reg, reg'	0 0 1 1 0 0 1 W		1 1 reg reg'	2	2	2	reg \leftarrow reg ∇ reg'	U	0	0	x	x	x
	mem, reg	0 0 1 1 0 0 0 W		mod reg mem	2-4	13/21	13/21	(mem) \leftarrow (mem) ∇ reg	U	0	0	x	x	x
	reg, mem	0 0 1 1 0 0 1 W		mod reg mem	2-4	10/14	10/14	reg \leftarrow reg ∇ (mem)	U	0	0	x	x	x
	reg, imm	1 0 0 0 0 0 0 W		1 1 1 1 0 reg	3-4	4	4	reg \leftarrow reg ∇ imm	U	0	0	x	x	x
	mem, imm	1 0 0 0 0 0 0 W		mod 1 1 0 mem	3-6	15/23	15/23	(mem) \leftarrow (mem) ∇ imm	U	0	0	x	x	x
	acc, imm	0 0 1 1 0 1 0 W			2-3	4	4	If W = 0: AL \leftarrow AL ∇ imm8 If W = 1: AW \leftarrow AW ∇ imm16	U	0	0	x	x	x

Instruc- tion Group	Mnemonic	Operand(s)	Operation Code		Bytes	Clock Cycles		Operation	Flags					
			7 6 5 4 3 2 1 0	7 6 5 4 3 2 1 0		V40HL	V50HL		AC	CY	V	P	S	Z
			Bit manipulation instructions	CLR1		reg8, CL	0 0 0 1 0 0 1 0		1 1 0 0 0 reg	3	5	5	reg8 bit NO.CL ← 0	
mem8, CL	0 0 1 0	mod 0 0 0 mem			3-5	11	11	(mem8) bit NO.CL ← 0						
reg16, CL	0 0 1 1	1 1 0 0 0 mem			3	5	5	reg16 bit NO.CL ← 0						
mem16, CL	0 0 1 1	mod 0 0 0 mem			3-5	19	11/19	(mem16) bit NO.CL ← 0						
reg8, imm3	1 0 1 0	1 1 0 0 0 reg			4	6	6	reg8 bit NO.imm3 ← 0						
mem8, imm3	1 0 1 0	mod 0 0 0 mem			4-6	12	12	(mem8) bit NO.imm3 ← 0						
reg16, imm4	1 0 1 1	1 1 0 0 0 reg			4	6	6	reg16 bit NO.imm4 ← 0						
mem16, imm4	1 0 1 1	mod 0 0 0 mem			4-6	20	12/20	(mem16) bit NO.imm4 ← 0						
SET1	reg8, CL	0 1 0 0		1 1 0 0 0 reg	3	4	4	reg8 bit NO.CL ← 1						
	mem8, CL	0 1 0 0		mod 0 0 0 mem	3-5	10	10	(mem8) bit NO.CL ← 1						
	reg16, CL	0 1 0 1		1 1 0 0 0 reg	3	4	4	reg16 bit NO.CL ← 1						
	mem16, CL	0 1 0 1		mod 0 0 0 mem	3-5	18	10/18	(mem16) bit NO.CL ← 1						
	reg8, imm3	1 1 0 0		1 1 0 0 0 reg	4	5	5	reg8 bit NO.imm3 ← 1						
	mem8, imm3	1 1 0 0		mod 0 0 0 mem	4-6	11	11	(mem8) bit NO.imm3 ← 1						
	reg16, imm4	1 1 0 1	1 1 0 0 0 reg	4	5	5	reg16 bit NO.imm4 ← 1							
	mem16, imm4	1 1 0 1	mod 0 0 0 mem	4-6	19	11/19	(mem16) bit NO.imm4 ← 1							

2nd byte*

3rd byte*

* 1st byte = 0FH

CLR1	CY	1 1 1 1 1 0 0 0		1	2	2	CY ← 0		0				
	DIR	1 1 1 1 1 1 0 0		1	2	2	DIR ← 0						
SET1	CY	1 1 1 1 1 0 0 1		1	2	2	CY ← 1		1				
	DIR	1 1 1 1 1 1 0 1		1	2	2	DIR ← 1						

Instruc- tion Group	Mnemonic	Operand(s)	Operation Code		Bytes	Clock Cycles		Operation	Flags					
			7 6 5 4 3 2 1 0	7 6 5 4 3 2 1 0		V40HL	V50HL		AC	CY	V	P	S	Z
			Shift instructions	SHL		reg, 1	1 1 0 1 0 0 0 W		1 1 1 0 0 reg	2	6	6	CY ← reg MSB, reg ← reg × 2 If reg MSB ≠ CY: V ← 1 If reg MSB = CY: V ← 0	U
	mem, 1	1 1 0 1 0 0 0 W		mod 1 0 0 mem	2-4	13/21	13/21	CY ← (mem) MSB, (mem) ← (mem) × 2 If (mem) MSB ≠ CY: V ← 1 If (mem) MSB = CY: V ← 0	U	×	×	×	×	×
	reg, CL	1 1 0 1 0 0 1 W		1 1 1 0 0 reg	2	7 + n	7 + n	temp ← CL, while temp ≠ 0 the following operation are repeated: CY ← reg MSB, reg ← reg × 2 temp ← temp - 1	U	×	U	×	×	×
	mem, CL	1 1 0 1 0 0 1 W		mod 1 0 0 mem	2-4	16/24 + n	16/24 + n	temp ← CL, while temp ≠ 0 the following operation are repeated: CY ← (mem) MSB, (mem) ← (mem) × 2 temp ← temp - 1	U	×	U	×	×	×
	reg, imm8	1 1 0 0 0 0 0 W		1 1 1 0 0 reg	3	7 + n	7 + n	temp ← imm8, while temp ≠ 0 the following operations are repeated: CY ← reg MSB, reg ← reg × 2 temp ← temp - 1	U	×	U	×	×	×
	mem, imm8	1 1 0 0 0 0 0 W		mod 1 0 0 mem	3-5	16/24 + n	16/24 + n	temp ← imm8, while temp ≠ 0 the following operations are repeated: CY ← (mem) MSB, (mem) ← (mem) × 2 temp ← temp - 1	U	×	U	×	×	×

n: Number of shifts

Instruc- tion Group	Mnemonic	Operand(s)	Operation Code		Bytes	Clock Cycles		Operation	Flags					
			7 6 5 4 3 2 1 0	7 6 5 4 3 2 1 0		V40HL	V50HL		AC	CY	V	P	S	Z
			Shift instructions	SHR		reg, 1	1 1 0 1 0 0 0 W		1 1 1 0 1 reg	2	6	6	CY ← reg LSB, reg ← reg ÷ 2 If reg MSB ≠ bit after reg MSB : V ← 1 If reg MSB = bit after reg MSB : V ← 0	U
	mem, 1	1 1 0 1 0 0 0 W		mod 1 0 1 mem	2-4	13/21	13/21	CY ← (mem) LSB, (mem) ← (mem) ÷ 2 If (mem) MSB ≠ bit after (mem) MSB : V ← 1 If (mem) MSB = bit after (mem) MSB : V ← 0	U	×	×	×	×	×
	reg, CL	1 1 0 1 0 0 1 W		1 1 1 0 1 reg	2	7 + n	7 + n	temp ← CL, while temp ≠ 0 the following operations are repeated: CY ← reg LSB, reg ← reg ÷ 2 temp ← temp - 1	U	×	U	×	×	×
	mem, CL	1 1 0 1 0 0 1 W		mod 1 0 1 mem	2-4	16/24 + n	16/24 + n	temp ← CL, while temp ≠ 0 the following operations are repeated: CY ← (mem) LSB, (mem) ← (mem) ÷ 2 temp ← temp - 1	U	×	U	×	×	×
	reg, imm8	1 1 0 0 0 0 0 W		1 1 1 0 1 reg	3	7 + n	7 + n	temp ← imm8, while temp ≠ 0 the following operations are repeated: CY ← reg LSB, reg ← reg ÷ 2 temp ← temp - 1	U	×	U	×	×	×
	mem, imm8	1 1 0 0 0 0 0 W		mod 1 0 1 mem	3-5	16/24 + n	16/24 + n	temp ← imm8, while temp ≠ 0 the following operations are repeated: CY ← (mem) LSB, (mem) ← (mem) ÷ 2 temp ← temp - 1	U	×	U	×	×	×

n: Number of shifts

Instruc- tion Group	Mnemonic	Operand(s)	Operation Code		Bytes	Clock Cycles		Operation	Flags						
			7 6 5 4 3 2 1 0	7 6 5 4 3 2 1 0		V40HL	V50HL		AC	CY	V	P	S	Z	
	SHRA	reg, 1	1 1 0 1 0 0 0 W	1 1 1 1 1 reg	2	6	6	CY ← reg LSB, reg ← reg ÷ 2, V ← 0 MSB of operand is unchanged.	U	×	0	×	×	×	
		mem, 1	1 1 0 1 0 0 0 W	mod 1 1 1 mem	2-4	13/21	13/21	CY ← (mem) LSB, (mem) ← (mem) ÷ 2, V ← 0 MSB of operand is unchanged.	U	×	0	×	×	×	
		reg, CL	1 1 0 1 0 0 1 W	1 1 1 1 1 reg	2	7 + n	7 + n	temp ← CL, while temp ≠ 0 the following operations are repeated: CY ← reg LSB, reg ← reg ÷ 2 temp ← temp - 1, MSB of operand is unchanged.	U	×	U	×	×	×	
		mem, CL	1 1 0 1 0 0 1 W	mod 1 1 1 mem	2-4	16/24 + n	16/24 + n	temp ← CL, while temp ≠ 0 the following operations are repeated: CY ← (mem) LSB, (mem) ← (mem) ÷ 2 temp ← temp - 1, MSB of operand is unchanged.	U	×	U	×	×	×	
		reg, imm8	1 1 0 0 0 0 0 W	1 1 1 1 1 reg	3	7 + n	7 + n	temp ← imm8, while temp ≠ 0 the following operations are repeated: CY ← reg LSB, reg ← reg ÷ 2 temp ← temp - 1, MSB of operand is unchanged.	U	×	U	×	×	×	
		mem, imm8	1 1 0 0 0 0 0 W	mod 1 1 1 mem	3-5	16/24 + n	16/24 + n	temp ← imm8, while temp ≠ 0 the following operations are repeated: CY ← (mem) LSB, (mem) ← (mem) ÷ 2 temp ← temp - 1, MSB of operand is unchanged.	U	×	U	×	×	×	

n: Number of shifts

Instruction Group	Mnemonic	Operand(s)	Operation Code		Bytes	Clock Cycles		Operation	Flags						
			7 6 5 4 3 2 1 0	7 6 5 4 3 2 1 0		V40HL	V50HL		AC	CY	V	P	S	Z	
			Rotate instructions	ROL		reg, 1	1 1 0 1 0 0 0 W		1 1 0 0 0 reg	2	6	6	CY ← reg MSB, reg ← reg × 2 + CY reg MSB ≠ CY : V ← 1 reg MSB = CY : V ← 0		×
	mem, 1	1 1 0 1 0 0 0 W		mod 0 0 0 mem	2-4	13/21	13/21	CY ← (mem) MSB, (mem) ← (mem) × 2 + CY (mem) MSB ≠ CY : V ← 1 (mem) MSB = CY : V ← 0		×	×				
	reg, CL	1 1 0 1 0 0 1 W		1 1 0 0 0 reg	2	7 + n	7 + n	temp ← CL, while temp ≠ 0 the following operations are repeated: CY ← reg MSB, reg ← reg × 2 + CY temp ← temp – 1		×	U				
	mem, CL	1 1 0 1 0 0 1 W		mod 0 0 0 mem	2-4	16/24 + n	16/24 + n	temp ← CL, while temp ≠ 0 the following operations are repeated: CY ← (mem) MSB, (mem) ← (mem) × 2 + CY temp ← temp – 1		×	U				
	reg, imm8	1 1 0 0 0 0 0 W		1 1 0 0 0 reg	3	7 + n	7 + n	temp ← imm8, while temp ≠ 0 the following operations are repeated: CY ← reg MSB, reg ← reg × 2 + CY temp ← temp – 1		×	U				
	mem, imm8	1 1 0 0 0 0 0 W		mod 0 0 0 mem	3-5	16/24 + n	16/24 + n	temp ← imm8, while temp ≠ 0 the following operations are repeated: CY ← (mem) MSB, (mem) ← (mem) × 2 + CY temp ← temp – 1		×	U				

n: Number of shifts

Instruc- tion Group	Mnemonic	Operand(s)	Operation Code		Bytes	Clock Cycles		Operation	Flags						
			7 6 5 4 3 2 1 0	7 6 5 4 3 2 1 0		V40HL	V50HL		AC	CY	V	P	S	Z	
			Rotate instructions	ROR		reg, 1	1 1 0 1 0 0 0 W		1 1 0 0 1 reg	2	6	6	CY ← reg LSB, reg ← reg ÷ 2 reg MSB ← CY reg MSB ≠ bit after reg MSB : V ← 1 reg MSB = bit after reg MSB : V ← 0		×
	mem, 1	1 1 0 1 0 0 0 W		mod 0 0 1 mem	2-4	13/21	13/21	CY ← (mem) LSB, (mem) ← (mem) ÷ 2 (mem) MSB ← CY (mem) MSB ≠ bit after (mem) MSB : V ← 1 (mem) MSB = bit after (mem) MSB : V ← 0		×	×				
	reg, CL	1 1 0 1 0 0 1 W		1 1 0 0 1 reg	2	7 + n	7 + n	temp ← CL, while CL ≠ 0 the following operations are repeated: CY ← reg LSB, reg ← reg ÷ 2 reg MSB ← CY temp ← temp - 1		×	U				
	mem, CL	1 1 0 1 0 0 1 W		mod 0 0 1 mem	2-4	16/24 + n	16/24 + n	temp ← CL, while CL ≠ 0 the following operations are repeated: CY ← (mem) LSB, (mem) ← (mem) ÷ 2 (mem) MSB ← CY temp ← temp - 1		×	U				
	reg, imm8	1 1 0 0 0 0 0 W		1 1 0 0 1 reg	3	7 + n	7 + n	temp ← imm8, while CL ≠ 0 the following operations are repeated: CY ← reg LSB, reg ← reg ÷ 2 reg MSB ← CY temp ← temp - 1		×	U				
	mem, imm8	1 1 0 0 0 0 0 W		mod 0 0 1 mem	3-5	16/24 + n	16/24 + n	temp ← imm8, while CL ≠ 0 the following operations are repeated: CY ← (mem) LSB, (mem) ← (mem) ÷ 2 (mem) MSB ← CY temp ← temp - 1		×	U				

n: Number of shifts

Instruction Group	Mnemonic	Operand(s)	Operation Code		Bytes	Clock Cycles		Operation	Flags						
			7 6 5 4 3 2 1 0	7 6 5 4 3 2 1 0		V40HL	V50HL		AC	CY	V	P	S	Z	
			Rotate instructions	ROL		reg, 1	1 1 0 1 0 0 0 W		1 1 0 1 0 reg	2	6	6	tmpcy ← CY, CY ← reg MSB reg ← reg × 2 + tmpcy reg MSB ≠ CY : V ← 1 reg MSB = CY : V ← 0		×
	mem, 1	1 1 0 1 0 0 0 W		mod 0 1 0 mem	2-4	13/21	13/21	tmpcy ← CY, CY ← (mem) MSB (mem) ← (mem) × 2 + tmpcy (mem) MSB ≠ CY : V ← 1 (mem) MSB = CY : V ← 0		×	×				
	reg, CL	1 1 0 1 0 0 1 W		1 1 0 1 0 reg	2	7 + n	7 + n	temp ← CL, while CL ≠ 0 the following operations are repeated: tmpcy ← CY, CY ← reg MSB reg ← reg × 2 + tmpcy temp ← temp - 1		×	U				
	mem, CL	1 1 0 1 0 0 1 W		mod 0 1 0 mem	2-4	16/24 + n	16/24 + n	temp ← CL, while CL ≠ 0 the following operations are repeated: tmpcy ← CY, CY ← (mem) MSB (mem) ← (mem) × 2 + tmpcy temp ← temp - 1		×	U				
	reg, imm8	1 1 0 0 0 0 0 W		1 1 0 1 0 reg	3	7 + n	7 + n	temp ← imm8, while CL ≠ 0 the following operations are repeated: tmpcy ← CY, CY ← reg MSB reg ← reg × 2 + tmpcy temp ← temp - 1		×	U				
	mem, imm8	1 1 0 0 0 0 0 W		mod 0 1 0 mem	3-5	16/24 + n	16/24 + n	temp ← imm8, while CL ≠ 0 the following operations are repeated: tmpcy ← CY, CY ← (mem) MSB (mem) ← (mem) × 2 + tmpcy temp ← temp - 1		×	U				

n: Number of shifts

Instruction Group	Mnemonic	Operand(s)	Operation Code		Bytes	Clock Cycles		Operation	Flags						
			7 6 5 4 3 2 1 0	7 6 5 4 3 2 1 0		V40HL	V50HL		AC	CY	V	P	S	Z	
			Rotate instructions	RORC		reg, 1	1 1 0 1 0 0 0 W		1 1 0 1 1 reg	2	6	6	tmpcy ← CY, CY ← reg LSB reg ← reg ÷ 2 reg MSB ← tmpcy reg MSB ≠ bit after reg MSB : V ← 1 reg MSB = bit after reg MSB : V ← 0		×
	mem, 1	1 1 0 1 0 0 0 W		mod 0 1 1 mem	2-4	13/21	13/21	tmpcy ← CY, CY ← (mem) LSB (mem) ← (mem) ÷ 2 (mem) MSB ← tmpcy (mem) MSB ≠ bit after (mem) MSB : V ← 1 (mem) MSB = bit after (mem) MSB : V ← 0		×	×				
	reg, CL	1 1 0 1 0 0 1 W		1 1 0 1 1 reg	2	7 + n	7 + n	temp ← CL, while CL ≠ 0 the following operations are repeated: tmpcy ← CY, CY ← reg LSB reg ← reg ÷ 2 reg MSB ← tmpcy temp ← temp - 1		×	U				
	mem, CL	1 1 0 1 0 0 1 W		mod 0 1 1 mem	2-4	16/24 + n	16/24 + n	temp ← CL, while CL ≠ 0 the following operations are repeated: tmpcy ← CY, CY ← (mem) LSB (mem) ← (mem) ÷ 2 (mem) MSB ← tmpcy temp ← temp - 1		×	U				
	reg, imm8	1 1 0 0 0 0 0 W		1 1 0 1 1 reg	3	7 + n	7 + n	temp ← imm8, while CL ≠ 0 the following operations are repeated: tmpcy ← CY, CY ← reg LSB reg ← reg ÷ 2 reg MSB ← tmpcy temp ← temp - 1		×	U				
	mem, imm8	1 1 0 0 0 0 0 W		mod 0 1 1 mem	3-5	16/24 + n	16/24 + n	temp ← imm8, while CL ≠ 0 the following operations are repeated: tmpcy ← CY, CY ← (mem) LSB (mem) ← (mem) ÷ 2 (mem) MSB ← tmpcy temp ← temp - 1		×	U				

n: Number of shifts

Instruction Group	Mnemonic	Operand(s)	Operation Code		Bytes	Clock Cycles		Operation	Flags					
			7 6 5 4 3 2 1 0	7 6 5 4 3 2 1 0		V40HL	V50HL		AC	CY	V	P	S	Z
			Subroutine control instructions	CALL		near-proc	1 1 1 0 1 0 0 0			3	20	16/20	SP ← SP - 2, (SP + 1, SP) ← PC PC ← PC + disp	
regptr16	1 1 1 1 1 1 1 1	1 1 0 1 0 reg			2	18	14/18	SP ← SP - 2, (SP + 1, SP) ← PC PC ← regptr16						
memptr16	1 1 1 1 1 1 1 1	mod 0 1 0 mem			2-4	31	23/31	TA ← (memptr16) SP ← SP - 2, (SP + 1, SP) ← PC, PC ← TA						
far-proc	1 0 0 1 1 0 1 0				5	29	21/29	SP ← SP - 2, (SP + 1, SP) ← PS, PS ← seg SP ← SP - 2, (SP + 1, SP) ← PC, PC ← offset						
memptr32	1 1 1 1 1 1 1 1	mod 0 1 1 mem			2-4	47	31/47	TA ← (memptr32), TB ← (memptr32 + 2) SP ← SP - 2, (SP + 1, SP) ← PS, PS ← TB SP ← SP - 2, (SP + 1, SP) ← PC, PC ← TA						
RET		1 1 0 0 0 0 1 1			1	19	15/19	PC ← (SP + 1, SP) SP ← SP + 2						
	pop-value	1 1 0 0 0 0 1 0			3	24	20/24	PC ← (SP + 1, SP) SP ← SP + 2, SP ← SP + pop-value						
		1 1 0 0 1 0 1 1			1	29	21/29	PC ← (SP + 1, SP) PS ← (SP + 3, SP + 2) PS ← SP + 4						
	pop-value	1 1 0 0 1 0 1 0			3	32	24/32	PC ← (SP + 1, SP) PS ← (SP + 3, SP + 2) SP ← SP + 4, SP ← SP + pop-value						

Instruc- tion Group	Mnemonic	Operand(s)	Operation Code		Bytes	Clock Cycles		Operation	Flags															
			7 6 5 4 3 2 1 0	7 6 5 4 3 2 1 0		V40HL	V50HL		AC	CY	V	P	S	Z										
			Stack manipulation instructions											PUSH	mem16	1 1 1 1 1 1 1 1	mod 1 1 0 mem	2-4	23	15/23	SP ← SP - 2 (SP + 1, SP) ← (mem16)			
reg16	0 1 0 1 0 reg														1	10	6/10	SP ← SP - 2 (SP + 1, SP) ← reg16						
sreg	0 0 0 sreg 1 1 0														1	10	6/10	SP ← SP - 2 (SP + 1, SP) ← sreg						
PSW	1 0 0 1 1 1 0 0														1	10	6/10	SP ← SP - 2 (SP + 1, SP) ← PSW						
R	0 1 1 0 0 0 0 0														1	65	33/65	Push registers on the stack						
imm8	0 1 1 0 1 0 1 0														2	9	5/9	SP ← SP - 2 (SP + 1, SP) ← imm8, sign of extension						
imm16	0 1 1 0 1 0 0 0														3	10	6/10	SP ← SP - 2 (SP + 1, SP) ← imm16						
POP	mem16	1 0 0 0 1 1 1 1												mod 0 0 0 mem	2-4	24	16/24	(mem16) ← (SP + 1, SP) SP ← SP + 2						
	reg16	0 1 0 1 1 reg													1	12	8/12	reg16 ← (SP + 1, SP) SP ← SP + 2						
	sreg	0 0 0 sreg 1 1 1													1	12	8/12	sreg ← (SP + 1, SP) SP ← SP + 2						
	PSW	1 0 0 1 1 1 0 1													1	12	8/12	PSW ← (SP + 1, SP) SP ← SP + 2	R	R	R	R	R	R
	R	0 1 1 0 0 0 0 1													1	75	43/75	Pop registers from the stack						
PREPARE	imm16, imm8	1 1 0 0 1 0 0 0													4	Note 1	Note 2	Prepare New Stack Frame						
DISPOSE		1 1 0 0 1 0 0 1													1	10	6/10	Dispose of Stack Frame						

- Notes 1.** If imm8 = 0 16
 If imm8 ≥ 1 21 + 16 (imm8 - 1)
- 2.** If imm8 = 0 12/16
 If imm8 ≥ 1 {17 + 8 (imm8 - 1)} / {21 + 16 (imm8 - 1)}

Instruction Group	Mnemonic	Operand(s)	Operation Code		Bytes	Clock Cycles		Operation	Flags					
			7 6 5 4 3 2 1 0	7 6 5 4 3 2 1 0		V40HL	V50HL		AC	CY	V	P	S	Z
			Branch instructions	BR		near-label	1 1 1 0 1 0 0 1			3	13	13	PC ← PC+ dsip	
short-label	1 1 1 0 1 0 1 1				2	12	12	PC ← PC+ ext-disp8						
regptr16	1 1 1 1 1 1 1 1	1 1 1 0 0 reg			2	11	11	PC ← regptr16						
memptr16	1 1 1 1 1 1 1 1	mod 1 0 0 mem			2-4	23	19/23	PC ← (memptr16)						
far-label	1 1 1 0 1 0 1 0				5	15	15	PS ← seg PC ← offset						
memptr32	1 1 1 1 1 1 1 1	mod 1 0 1 mem			2-4	34	26/34	PS ← (memptr32 + 2) PC ← (memptr32)						

Instruc- tion Group	Mnemonic	Operand(s)	Operation Code		Bytes	Clock Cycles ^{Note}		Operation	Flags						
			7 6 5 4 3 2 1 0	7 6 5 4 3 2 1 0		V40HL	V50HL		AC	CY	V	P	S	Z	
			Conditional branch instructions	BV		short-label	0 1 1 1 0 0 0 0			2	14/4	14/4	if V = 1	PC ← PC + ext-disp8	
BNV	short-label			0 0 0 1	2	14/4	14/4	if V = 0	PC ← PC + ext-disp8						
BC BL	short-label			0 0 1 0	2	14/4	14/4	if CY = 1	PC ← PC + ext-disp8						
BNC BNL	short-label			0 0 1 1	2	14/4	14/4	if CY = 0	PC ← PC + ext-disp8						
BE BZ	short-label			0 1 0 0	2	14/4	14/4	if Z = 1	PC ← PC + ext-disp8						
BNE BNZ	short-label			0 1 0 1	2	14/4	14/4	if Z = 0	PC ← PC + ext-disp8						
BNH	short-label			0 1 1 0	2	14/4	14/4	if CY ∨ Z = 1	PC ← PC + ext-disp8						
BH	short-label			0 1 1 1	2	14/4	14/4	if CY ∨ Z = 0	PC ← PC + ext-disp8						
BN	short-label			1 0 0 0	2	14/4	14/4	if S = 1	PC ← PC + ext-disp8						
BP	short-label			1 0 0 1	2	14/4	14/4	if S = 0	PC ← PC + ext-disp8						
BPE	short-label			1 0 1 0	2	14/4	14/4	if P = 1	PC ← PC + ext-disp8						
BPO	short-label			1 0 1 1	2	14/4	14/4	if P = 0	PC ← PC + ext-disp8						
BLT	short-label			1 1 0 0	2	14/4	14/4	if S ∨ V = 1	PC ← PC + ext-disp8						
BGE	short-label			1 1 0 1	2	14/4	14/4	if S ∨ V = 0	PC ← PC + ext-disp8						
BLE	short-label			1 1 1 0	2	14/4	14/4	if (S ∨ V) ∨ Z = 1	PC ← PC + ext-disp8						
BGT	short-label			1 1 1 1	2	14/4	14/4	if (S ∨ V) ∨ Z = 0	PC ← PC + ext-disp8						
DBNZNE	short-label			1 1 1 0 0 0 0 0		2	14/5	14/5	CW = CW - 1 if Z = 0 and CW ≠ 0	PC ← PC + ext-disp8					
DBNZE	short-label			1 1 1 0 0 0 0 1		2	14/5	14/5	CW = CW - 1 if Z = 1 and CW ≠ 0	PC ← PC + ext-disp8					
DBNZ	short-label		1 1 1 0 0 0 1 0		2	13/5	13/5	CW = CW - 1 if CW ≠ 0	PC ← PC + ext-disp8						
BCWZ	short-label		1 1 1 0 0 0 1 1		2	13/5	13/5	if CW = 0	PC ← PC + ext-disp8						

Note Condition determination: true/false

Instruc- tion Group	Mnemonic	Operand(s)	Operation Code		Bytes	Clock Cycles		Operation	Flags						
			7 6 5 4 3 2 1 0	7 6 5 4 3 2 1 0		V40HL	V50HL		AC	CY	V	P	S	Z	
			Interrupt instructions	BRK		3	1 1 0 0 1 1 0 0			1	50	38/50	TA ← (00DH, 00CH), TC ← (00FH, 00EH) SP ← SP - 2, (SP + 1, SP) ← PSW, IE ← 0, BRK ← 0 SP ← SP - 2, (SP + 1, SP) ← PS, PS ← TC SP ← SP - 2, (SP + 1, SP) ← PC, PC ← TA		
	imm8 (= 3)	1 1 0 0 1 1 0 1			2	50	38/50	TA ← (4n + 1, 4n), TC ← (4n + 3, 4n + 2) n = imm8 SP ← SP - 2, (SP + 1, SP) ← PSW, IE ← 0, BRK ← 0 SP ← SP - 2, (SP + 1, SP) ← PS, PS ← TC SP ← SP - 2, (SP + 1, SP) ← PC, PC ← TA							
BRKV		1 1 0 0 1 1 1 0			1	Note 1	Note 2	If V = 1 TA ← (011H, 010H), TC ← (013H, 012H) SP ← SP - 2, (SP + 1, SP) ← PSW, IE ← 0, BRK ← 0 SP ← SP - 2, (SP + 1, SP) ← PS, PS ← TC SP ← SP - 2, (SP + 1, SP) ← PC, PC ← TA							
RETI		1 1 0 0 1 1 1 1			1	39	27/39	PC ← (SP + 1, SP), PS ← (SP + 3, SP + 2), PSW ← (SP + 5, SP + 4), SP ← SP + 6	R	R	R	R	R	R	R
BRKEM	imm8	0 0 0 0 1 1 1 1		1 1 1 1 1 1 1 1	3	50	38/50	TA ← (4n + 1, 4n), TC ← (4n + 3, 4n + 2) n = imm8 SP ← SP - 2, (SP + 1, SP) ← PSW, MD ← 0 MD is set to write enabled SP ← SP - 2, (SP + 1, SP) ← PS, PS ← TC SP ← SP - 2, (SP + 1, SP) ← PC, PC ← TA							
CHKIND	reg16, mem32	0 1 1 0 0 0 1 0		mod reg mem	2-4	Note 3	Note 4	If (mem32) > reg16 or (mem32 + 2) < reg16 TA ← (015H, 014H), TC ← (017H, 016H) SP ← SP - 2, (SP + 1, SP) ← PSW, IE ← 0, BRK ← 0 SP ← SP - 2, (SP + 1, SP) ← PS, PS ← TC SP ← SP - 2, (SP + 1, SP) ← PC, PC ← TA							

- Notes**
- When V = 1: 52
When V = 0: 3
 - When V = 1: 40/52
When V = 0: 3
 - When interrupt condition is established : 72 to 75
When interrupt condition is not established : 25
 - When interrupt condition is established : (52 to 55)/(72 to 75)
When interrupt condition is not established : 17/25

Instruction Group	Mnemonic	Operand(s)	Operation Code		Bytes	Clock Cycles		Operation	Flags							
			7 6 5 4 3 2 1 0	7 6 5 4 3 2 1 0		V40HL	V50HL		AC	CY	V	P	S	Z		
			CPU control instructions	HALT			1 1 1 1 0 1 0 0			1	2	2	CPU Halt			
POLL		1 0 0 1 1 0 1 1			1	2 + 5n	2 + 5n	Poll and wait n: Number of times $\overline{\text{POLL}}$ pin is sampled								
DI		1 1 1 1 1 0 1 0			1	2	2	IE ← 0								
EI		1 1 1 1 1 0 1 1			1	2	2	IE ← 1								
BUSLOCK		1 1 1 1 0 0 0 0			1	2	2	Bus Lock Prefix								
FPO1	fp-op			1 1 0 1 1 X X X	1 1 Y Y Y Z Z Z	2	2	2	No Operation							
	fp-op, mem			1 1 0 1 1 X X X	mod Y Y Y mem	2-4	14	10/14	data bus ← (mem)							
FPO2	fp-op			0 1 1 0 0 1 1 X	1 1 Y Y Y Z Z Z	2	2	2	No Operation							
	fp-op, mem			0 1 1 0 0 1 1 X	mod Y Y Y mem	2-4	14	10/14	data bus ← (mem)							
NOP			1 0 0 1 0 0 0 0		1	3	3	No Operation								

	*		0 0 1 sreg 1 1 0		1	2	2	Segment override prefix							
--	---	--	------------------	--	---	---	---	-------------------------	--	--	--	--	--	--	--

* DS0:, DS1:, PS:, and SS:.

Instruction Group	Mnemonic	Operand(s)	Operation Code		Bytes	Clock Cycles		Operation	Flags					
			7 6 5 4 3 2 1 0	7 6 5 4 3 2 1 0		V40HL	V50HL		AC	CY	V	P	S	Z
			8080	RETEM			1 1 1 0 1 1 0 1		1 1 1 1 1 1 0 1	2	39	27/39	PC ← (SP + 1, SP), PS ← (SP + 3, SP + 2), PSW ← (SP + 5, SP + 4), SP ← SP + 6, MD is set to write disabled	R
CALLN	imm8	1 1 1 0 1 1 0 1		1 1 1 0 1 1 0 1	3	58	38/58	TA ← (4n + 1, 4n), TC ← (4n + 3, 4n + 2) n = imm8 SP ← SP - 2, (SP + 1, SP) ← PSW, MD ← 1 SP ← SP - 2, (SP + 1, SP) ← PS, PS ← TC SP ← SP - 2, (SP + 1, SP) ← PC, PC ← TA						

16. ELECTRICAL SPECIFICATIONS

Applied standard

The electrical characteristics shown below are applied to devices other than the old models conforming to K mask.

Therefore, these characteristics are different from those conforming to the K mask. For the electrical characteristics of the K mask, consult NEC.

“Others” in the table below means products conforming to the masks other than E, P, X, and M (but conforming to the L, F mask).

16.1 AT 5 V OPERATION

OPERATING RANGE

	E, P, X, M Mask Model	Others
μPD70208H, 70216H-10/12/16	V _{DD} = 5 V ±10%	
μPD70208H, 70216H-20	—	V _{DD} = 5 V ±5%

ABSOLUTE MAXIMUM RATINGS (T_A = 25 °C)

Parameter	Symbol	Test Conditions	Rating	Unit
Supply voltage	V _{DD}		-0.5 to +7.0	V
Input voltage	V _I	V _{DD} = 5 V ±10%	-0.5 to V _{DD} + 0.3	V
Clock input voltage	V _K	(μPD70208H, 70216H-10/12/16)	-0.5 to V _{DD} + 1.0	V
Output voltage	V _O	V _{DD} = 5 V ±5% (μPD70208H, 70216H-20)	-0.5 to V _{DD} + 0.3	V
Operating ambient temperature	T _A		-40 to +85	°C
Storage temperature	T _{stg}		-65 to +150	°C

- Cautions**
1. Do not directly connect the output pins of two or more IC products and do not directly connect the output pins to V_{DD} or V_{CC} and GND. However, open-drain pins or open-collector pins may be connected directly. Moreover, an external circuit whose timing is designed to avoid output collision can be connected to pins that go into a high-impedance state.
 2. If even one of the above parameters exceeds the absolute maximum rating even momentarily, the quality of the program may be degraded. Absolute maximum ratings, therefore, are the values exceeding which the product may be physically damaged. Use the program keeping all the parameters within these rated values.

The standards and conditions shown in DC and AC Characteristics below specify the range within which the normal operation of the product is guaranteed.

DC CHARACTERISTICS

(T_A = -40 to +85 °C, V_{DD} = 5 V ±10% (μPD70208H, 70216H-10/12/16), V_{DD} = 5 V ±5% (μPD70208H, 70216H-20))

Parameter	Symbol	Test Conditions		MIN.	TYP.	MAX.	Unit
Input voltage high	V _{IH}	E, P, X, M masks	Except $\overline{\text{RESET}}$	2.2		V _{DD} +0.3	V
			$\overline{\text{RESET}}$	0.8 V _{DD}		V _{DD} +0.3	
		Others	Except $\overline{\text{RESET}}$, INTP1 to INTP7	2.2		V _{DD} +0.3	
			$\overline{\text{RESET}}$	0.8 V _{DD}		V _{DD} +0.3	
			INTP1 to INTP7	2.4		V _{DD} +0.3	
Input voltage low	V _{IL}	Except $\overline{\text{RESET}}$		-0.5		+0.8	V
		$\overline{\text{RESET}}$		-0.5		0.2V _{DD}	
Clock input voltage high	V _{KH}			3.9		V _{DD} +1.0	V
Clock input voltage low	V _{KL}			-0.5		+0.6	V
Output voltage high	V _{OH}	I _{OH} = -2.5 mA		0.7 V _{DD}			V
		I _{OH} = -100 μA		V _{DD} - 0.4			
Output voltage low	V _{OL}	Except $\overline{\text{END/TC}}$: I _{OL} = 2.5 mA				0.4	V
		$\overline{\text{END/TC}}$: I _{OL} = 5.0 mA					
Input leak current high	I _{LIH}	V _I = V _{DD}				10	μA
Input leak current low	I _{LIL}	Except INTP: V _I = 0 V				-10	μA
INTP input current low	I _{LIPL}	INTP input: V _I = 0 V				-300	μA
Output leak current high	I _{LOH}	V _O = V _{DD}				10	μA
Output leak current low	I _{LOL}	V _O = 0 V				-10	μA
Latch leak current high	I _{LLH}	V _I = 3.0 V		-50		-300	μA
Latch leak current low	I _{LLL}	V _I = 0.8 V		50		300	μA
Latch inversion current (L → H)	I _{LH}					400	μA
Latch inversion current (H → L)	I _{LL}					-400	μA
Supply current ^{Note}	I _{DD}	E, P, X, M masks	On operation		5.5 f _x	9.0 f _x	mA
			On standby (HALT)		1.5 f _x	2.5 f _x	
			On standby (STOP)			50	
		Others	On operation		4.5 f _x	6.0 f _x	mA
			On standby (HALT)		1.5 f _x	2.2 f _x	
			On standby (STOP)			50	

Note The unit of constant values (1.5, 2.2, 2.5, 4.5, 5.5, 6.0 and 9.0) is mA/MHz.

CAPACITANCE (T_A = 25 °C, V_{DD} = 0 V)

Parameter	Symbol	Test Conditions	MIN.	TYP.	MAX.	Unit
Input capacitance	C _I	f _c = 1 MHz			10	pF
Input/output capacitance	C _{IO}	0 V other than test pin.			15	pF

AC CHARACTERISTICS

(1) μPD70208H, 70216H-10/12/16 (T_A = -40 to +85 °C, V_{DD} = 5 V ±10%) (1/3)

Output Pin Load Capacitance: C_L = 100 pF

Parameter	Symbol		μPD70208H-10		μPD70208H-12		μPD70208H-16		Unit
			μPD70216H-10		μPD70216H-12		μPD70216H-16		
			MIN.	MAX.	MIN.	MAX.	MIN.	MAX.	
External clock input cycle	<1>	t _{CYX}	50	DC	40	DC	31.25	DC	ns
External clock input high-level width (V _{KH} =3.0 V)	<2>	t _{XH}	19		14		12		ns
External clock input low-level width (V _{KL} =1.5 V)	<3>	t _{XL}	19		14		12		ns
External clock input rise time (1.5→3.0 V)	<4>	t _{XR}		5		5		5	ns
External clock input fall time (3.0→1.5 V)	<5>	t _{XF}		5		5		5	ns
Clock output cycle	<6>	t _{CYK}	100	DC	80	DC	62.5	DC	ns
Clock output high-level width (V _{OH} =3.0 V)	<7>	t _{KH}	0.5t _{CYK} -5		0.5t _{CYK} -5		0.5t _{CYK} -5		ns
Clock output low-level width (V _{OL} =1.5 V)	<8>	t _{KL}	0.5t _{CYK} -5		0.5t _{CYK} -5		0.5t _{CYK} -5		ns
Clock output rise time (1.5→3.0 V)	<9>	t _{KR}		5		5		5	ns
Clock output fall time (3.0→1.5 V)	<10>	t _{KF}		5		5		5	ns
CLKOUT delay time (vs. external clock)	<11>	t _{DXK}		40		35		20	ns
Input rise time (except external clock) (0.8→2.2 V)	<12>	t _{IR}		15		15		15	ns
Input fall time (except external clock) (2.2→0.8 V)	<13>	t _{IF}		10		10		10	ns
Output rise time (except CLKOUT) (0.8→2.2 V)		E, P, X, M masks	<14>	t _{OR}		15		15	ns
		Others		10		10		10	
Output fall time (except CLKOUT) (2.2→0.8 V)	<15>	t _{OF}		10		10		10	ns
RESET setup time (vs. CLKOUT↓) ^{Note 1}	<16>	t _{SRESK}	20		20		20		ns
RESET hold time (vs. CLKOUT↓) ^{Note 1}	<17>	t _{HKRES}	25		25		15		ns
RESOUT output delay time (vs. CLKOUT↓)	<18>	t _{DKRES}	5	50	5	40	5	30	ns
READY inactive setup time (vs. CLKOUT↑)	<19>	t _{SRYLK}	15		10		7		ns
READY inactive hold time (vs. CLKOUT↑)	<20>	t _{HKRYL}	20		15		15		ns
READY active setup time (vs. CLKOUT↑)	<21>	t _{SRYHK}	15		10		7		ns
READY active hold time (vs. CLKOUT↑)	<22>	t _{HKRYH}	20		20		15		ns
NMI setup time (vs. CLKOUT↑)	<23>	t _{SNMIK}	15		15		15		ns
POLL setup time (vs. CLKOUT↑)	<24>	t _{SPOLK}	20		20		20		ns
Data setup time (vs. CLKOUT↓)	<25>	t _{SDK}	15		10		7		ns
Data hold time (vs. CLKOUT↓)	<26>	t _{HKD}	5		5		5		ns
CLKOUT → address delay time ^{Note 2}	<27>	t _{DKA}	5	50	5	40	5	28	ns
★ CLKOUT → address hold time	<28>	t _{HKA}	5		5		5		ns
CLKOUT↓ → PS delay time	<29>	t _{DKP}	5	50	5	40	5	30	ns
CLKOUT↓ → PS float delay time	<30>	t _{FKP}	5	50	5	40	5	30	ns
Address setup time (vs. ASTB↓)	<31>	t _{SAST}	t _{KKL} -20		t _{KKL} -10		t _{KKL} -10		ns
CLKOUT↓ → address float delay time ^{Note 3}	<32>	t _{FKA}	t _{HKA}	50	t _{HKA}	40	t _{HKA}	30	ns
CLKOUT↓ → ASTB↑ delay time	<33>	t _{DKSTH}		40		30		25	ns

- Notes**
1. When reset with the minimum pulse width or when guaranteeing the RESOUT output timing.
 2. Specifications also corresponding to the QS0, QS1, and BUSLOCK signals, and A16/PS0-A19/PS3, \overline{UBE} , \overline{BUFEN} , $\overline{BUFR/W}$, \overline{MRD} , \overline{IORD} , \overline{MWR} , \overline{IOWR} , and BS0-BS2 signals at HLDRQ/HLDAK timing.
 3. Specifications also corresponding to the A16/PS0-A19/PS3, \overline{UBE} , \overline{BUFEN} , $\overline{BUFR/W}$, \overline{MRD} , \overline{IORD} , \overline{MWR} , \overline{IOWR} , and BS0-BS2 signals at HLDRQ/HLDAK timing.

(1) μPD70208H, 70216H-10/12/16 (T_A = -40 to +85 °C, V_{DD} = 5 V ±10%) (2/3)

Output Pin Load Capacitance: C_L = 100 pF

Parameter	Symbol	μPD70208H-10 μPD70216H-10		μPD70208H-12 μPD70216H-12		μPD70208H-16 μPD70216H-16		Unit
		MIN.	MAX.	MIN.	MAX.	MIN.	MAX.	
CLKOUT↑ → ASTB↓ delay time	<34> t _{DKSTL}		45		35		30	ns
ASTB high-level width	<35> t _{STST}	t _{KKL} -10		t _{KKL} -10		t _{KKL} -10		ns
ASTB↓ → address hold time	<36> t _{HSTA}	t _{KKH} -20		t _{KKH} -10		t _{KKH} -10		ns
CLKOUT → control 1 ^{Note 1} delay time	<37> t _{DKCT1}	5	60	5	50	5	40	ns
CLKOUT → control 2 ^{Note 2} delay time	<38> t _{DKCT2}	5	55	5	45	5	35	ns
Address float → \overline{RD} ↓ delay time	<39> t _{DAFRL}	0		0		0		ns
CLKOUT↓ → \overline{RD} ↓ delay time	<40> t _{DKRL}	5	65	5	50	5	40	ns
CLKOUT↓ → \overline{RD} ↑ delay time	<41> t _{DKRH}	5	60	5	45	5	35	ns
\overline{RD} ↑ → address delay time	<42> t _{DRHA}	t _{CYK} -40		t _{CYK} -20		t _{CYK} -10		ns
\overline{RD} low-level width	<43> t _{RR}	2t _{CYK} -40		2t _{CYK} -20		2t _{CYK} -20		ns
\overline{BUFEN} ↑ → \overline{BUIFR}/W delay time (read cycle)	<44> t _{DBECT}	t _{KKL} -20		t _{KKL} -10		t _{KKL} -10		ns
CLKOUT↓ → data output delay time	<45> t _{DKD}	5	55	5	40	5	30	ns
CLKOUT↓ → data float delay time	<46> t _{FKD}	5	55	5	40	5	30	ns
\overline{WR} low-level width	<47> t _{WW}	2t _{CYK} -40		2t _{CYK} -20		2t _{CYK} -20		ns
\overline{WR} ↑ → \overline{BUIFR} ↑ or \overline{BUIFR}/W ↓ (write cycle)	<48> t _{DWCT}	t _{KKL} -20		t _{KKL} -10		t _{KKL} -10		ns
CLKOUT↑ → BS↓ delay time	<49> t _{DKBL}	5	55	5	40	5	30	ns
CLKOUT↓ → BS↑ delay time	<50> t _{DKBH}	5	55	5	40	5	30	ns
HLD _{RQ} setup time (vs. CLKOUT↓)	<51> t _{SHQK}	15		10		7		ns
CLKOUT↓ → HLD _{AK} delay time	<52> t _{DKHA}	5	60	5	50	5	40	ns
CLKOUT↑ → \overline{DMAAK} delay time	<53> t _{DKHDA}	5	55	5	45	5	35	ns
CLKOUT↓ → \overline{DMAAK} delay time (cascade mode)	<54> t _{DKLDA}	5	80	5	70	5	55	ns
\overline{WR} low-level width (DMA cycle)	DMA extended write	<55> t _{WW1}	2t _{CYK} -40		2t _{CYK} -20		2t _{CYK} -20	ns
	DMA normal write	<56> t _{WW2}	t _{CYK} -40		t _{CYK} -20		t _{CYK} -15	ns
\overline{RD} ↓, \overline{WR} ↓ delay time (vs. \overline{DMAAK} ↓)	<57> t _{DDARW}	t _{KKH} -30		t _{KKH} -20		t _{KKH} -15		ns
\overline{DMAAK} ↑ delay time (vs. \overline{RD} ↑)	<58> t _{DRHDAH}	t _{KKL} -30		t _{KKL} -20		t _{KKL} -15		ns
\overline{RD} ↑ delay time (vs. \overline{WR} ↑)	<59> t _{DWHRH}	3		3		3		ns
\overline{TC} output delay time (vs. CLKOUT↑)	<60> t _{DKTCL}		55		45		35	ns
\overline{TC} OFF delay time (vs. CLKOUT↑)	<61> t _{DKTCF}		55		45		35	ns
\overline{TC} low-level width	<62> t _{TCTCL}	t _{CYK} -15		t _{CYK} -10		t _{CYK} -10		ns
\overline{TC} pull-up delay time (vs. CLKOUT↑)	<63> t _{DKTCH}		Note 3		Note 4		Note 4	ns
\overline{END} setup time (vs. CLKOUT↑)	<64> t _{SEDK}	30		25		20		ns
\overline{END} low-level width	<65> t _{EDEL}	80		65		50		ns
DMARQ setup time (vs. CLKOUT↑)	<66> t _{SDQK}	30		20		15		ns
INTP _n low-level width	<67> t _{PIPL}	80		80		80		ns
RxD setup time (vs. SCU internal clock↓)	<68> t _{SRX}	500		500		500		ns

- Notes**
1. \overline{MWR} and \overline{IOWR} signals in DMA cycle
 2. \overline{MWR} and \overline{IOWR} signals in CPU cycles and \overline{BUIFR} , \overline{BUIFR}/W , \overline{INTAK} and \overline{REFRQ} signals.
 3. t_{KKH} + 2t_{CYK} - 10 (Reference value when a 1.1-kΩ pull-up resistor is connected.)
 4. t_{KKH} + 2t_{CYK} - 5 (Reference value when a 1.1-kΩ pull-up resistor is connected.)

(1) μPD70208H, 70216H-10/12/16 (T_A = -40 to +85 °C, V_{DD} = 5 V ±10%) (3/3)

Output Pin Load Capacitance: C_L = 100 pF

Parameter	Symbol		μPD70208H-10		μPD70208H-12		μPD70208H-16		Unit
			μPD70216H-10		μPD70216H-12		μPD70216H-16		
			MIN.	MAX.	MIN.	MAX.	MIN.	MAX.	
RxD hold time (vs. SCU internal clock↓)	<69>	t _{HRX}	500		500		500		ns
CLKOUT↓ → $\overline{\text{SRDY}}$ delay time	<70>	t _{DKSR}		100		100		100	ns
TOUT1↓ → TxD delay time	<71>	t _{DTX}		200		200		200	ns
TCTL2 setup time (vs. CLKOUT↓)	<72>	t _{SGK}	40		40		40		ns
TCTL2 setup time (vs. TCLK↑)	<73>	t _{SGTK}	40		40		40		ns
TCTL2 hold time (vs. CLKOUT↓)	<74>	t _{HKG}	80		80		80		ns
TCTL2 hold time (vs. TCLK↑)	<75>	t _{HTKG}	40		40		40		ns
TCTL2 high-level width	<76>	t _{GGH}	40		40		40		ns
TCTL2 low-level width	<77>	t _{GGL}	40		40		40		ns
TOUT output delay time (vs. CLKOUT↓)	<78>	t _{DKTO}		150		150		150	ns
TOUT output delay time (vs. TCLK↓)	<79>	t _{DTKTO}		100		100		100	ns
TOUT output delay time (vs. TCTL2↓)	<80>	t _{DGTO}		90		90		90	ns
TCLK rise time	<81>	t _{TKR}		25		25		25	ns
TCLK fall time	<82>	t _{TKF}		25		25		25	ns
TCLK high-level width	<83>	t _{TKTKH}	45		40		30		ns
TCLK low-level width	<84>	t _{TKTKL}	45		40		30		ns
TCLK cycle	<85>	t _{CYTK}	100	DC	80	DC	62.5	DC	ns
Access interval ^{Note 1}	<86>	t _{AI}	2t _{CYK} -40		2t _{CYK} -25		2t _{CYK} -20		ns
$\overline{\text{REFRQ}}\uparrow$ delay time (vs. $\overline{\text{MRD}}\uparrow$) ^{Note 2}	<87>	t _{DROHRH}	t _{KKL} -30		t _{KKL} -15		t _{KKL} -10		ns
$\overline{\text{RESET}}$ pulse width ^{Note 3}	<88>	t _{WRESL}	4t _{CYK}		4t _{CYK}		4t _{CYK}		ns

- Notes**
1. Specification to guarantee read/write recovery time for I/O device.
 2. Specification to guarantee that $\overline{\text{REFRQ}}\uparrow$ is always later than $\overline{\text{MRD}}\uparrow$.
Only guaranteed when the EREF bit of the SCTL register is 0.
 3. When using internal clock generator by connecting a resonator to the X1 and X2 pins, the oscillation stabilization time must be added at power-ON. Because the oscillation stabilization time varies depending on the characteristics of the resonator and oscillator used, evaluate the oscillation stabilization time with the resonator and oscillator actually used.

(2) μPD70208H, 70216H-20 (T_A = -40 to +85 °C, V_{DD} = 5 V ±5%) (1/3)

Output Pin Load Capacitance: C_L = 100 pF

Parameter	Symbol	μPD70208H-20 μPD70216H-20		Unit
		MIN.	MAX.	
External clock input cycle	<1> t _{CYX}	25	DC	ns
External clock input high-level width (V _{KH} =3.0 V)	<2> t _{XH}	10		ns
External clock input low-level width (V _{KL} =1.5 V)	<3> t _{XL}	10		ns
External clock input rise time (1.5→3.0 V)	<4> t _{XR}		5	ns
External clock input fall time (3.0→1.5 V)	<5> t _{XF}		5	ns
Clock output cycle	<6> t _{CYK}	50	DC	ns
Clock output high-level width (V _{OH} =3.0 V)	<7> t _{KKH}	0.5t _{CYK} -5		ns
Clock output low-level width (V _{OL} =1.5 V)	<8> t _{KKL}	0.5t _{CYK} -5		ns
Clock output rise time (1.5→3.0 V)	<9> t _{KR}		5	ns
Clock output fall time (3.0→1.5 V)	<10> t _{KF}		5	ns
CLKOUT delay time (vs. external clock)	<11> t _{D_{XK}}		20	ns
Input rise time (except external clock) (0.8→2.2 V)	<12> t _{IR}		15	ns
Input fall time (except external clock) (2.2→0.8 V)	<13> t _{IF}		10	ns
Output rise time (except CLKOUT) (0.8→2.2 V)	<14> t _{OR}		10	ns
Output fall time (except CLKOUT) (2.2→0.8 V)	<15> t _{OF}		10	ns
RESET setup time (vs. CLKOUT↓) Note 1	<16> t _{SRESK}	20		ns
RESET hold time (vs. CLKOUT↓) Note 1	<17> t _{HKRES}	10		ns
RESOUT output delay time (vs. CLKOUT↓)	<18> t _{DKRES}	5	25	ns
READY inactive setup time (vs. CLKOUT↑)	<19> t _{SRYLK}	7		ns
READY inactive hold time (vs. CLKOUT↑)	<20> t _{HKRYL}	10		ns
READY active setup time (vs. CLKOUT↑)	<21> t _{SRYHK}	7		ns
READY active hold time (vs. CLKOUT↑)	<22> t _{HKRYH}	10		ns
NMI setup time (vs. CLKOUT↑)	<23> t _{SNMK}	10		ns
POLL setup time (vs. CLKOUT↑)	<24> t _{SPOLK}	20		ns
Data setup time (vs. CLKOUT↓)	<25> t _{SDK}	7		ns
Data hold time (vs. CLKOUT↓)	<26> t _{HKD}	5		ns
CLKOUT → address delay time Note 2	<27> t _{DKA}	5	25	ns
★ CLKOUT → address hold time	<28> t _{HKA}	5		ns
CLKOUT ↓ → PS delay time	<29> t _{DKP}	5	30	ns
CLKOUT ↓ → PS float delay time	<30> t _{FKP}	5	30	ns
Address setup time (vs. ASTB↓)	<31> t _{SAST}	t _{KKL} -10		ns
CLKOUT ↓ → address float delay time Note 3	<32> t _{FKA}	t _{HKA}	25	ns
CLKOUT ↓ → ASTB ↑ delay time	<33> t _{DKSTH}		20	ns
CLKOUT ↑ → ASTB ↓ delay time	<34> t _{DKSTL}		20	ns
ASTB high-level width	<35> t _{TST}	t _{KKL} -10		ns

- Notes**
1. When reset with the minimum pulse width or when guaranteeing the RESOUT output timing.
 2. Specifications also corresponding to the QS0, QS1, and BUSLOCK signals, and A16/PS0-A19/PS3, \overline{UBE} , \overline{BUFEN} , \overline{BUFR}/W , \overline{MRD} , \overline{IORD} , \overline{MWR} , \overline{IOWR} , and BS0-BS2 signals at HLDRQ/HLDAK timing.
 3. Specifications also corresponding to the A16/PS0-A19/PS3, \overline{UBE} , \overline{BUFEN} , \overline{BUFR}/W , \overline{MRD} , \overline{IORD} , \overline{MWR} , \overline{IOWR} , and BS0-BS2 signals at HLDRQ/HLDAK timing.

(2) μPD70208H, 70216H-20 (T_A = -40 to +85 °C, V_{DD} = 5 V ±5%) (2/3)

Output Pin Load Capacitance: C_L = 100 pF

Parameter	Symbol	μPD70208H-20 μPD70216H-20		Unit
		MIN.	MAX.	
ASTB ↓ → address hold time	<36> t _{HSTA}	t _{KKH} -10		ns
CLKOUT → control 1 ^{Note 1} delay time	<37> t _{DKCT1}	5	25	ns
CLKOUT → control 2 ^{Note 2} delay time	<38> t _{DKCT2}	5	30	ns
Address float → \overline{RD} ↓ delay time	<39> t _{DAFRL}	0		ns
CLKOUT ↓ → \overline{RD} ↓ delay time	<40> t _{DKRL}	5	25	ns
CLKOUT ↓ → \overline{RD} ↑ delay time	<41> t _{DKRH}	5	28	ns
\overline{RD} ↑ → address delay time	<42> t _{DRHA}	t _{CYK} -5		ns
\overline{RD} low-level width	<43> t _{RR}	2t _{CYK} -15		ns
\overline{BUFEN} ↑ → $\overline{BUF\overline{R}/W}$ delay time (read cycle)	<44> t _{DBECT}	t _{KKL} -10		ns
CLKOUT ↓ → data output delay time	<45> t _{DKD}	5	25	ns
CLKOUT ↓ → data float delay time	<46> t _{FKD}	5	25	ns
\overline{WR} low-level width	<47> t _{WW}	2t _{CYK} -15		ns
\overline{WR} ↑ → \overline{BUFEN} ↑ or $\overline{BUF\overline{R}/W}$ ↓ (write cycle)	<48> t _{DWCT}	t _{KKL} -10		ns
CLKOUT ↑ → BS ↓ delay time	<49> t _{DKBL}	5	30	ns
CLKOUT ↓ → BS ↑ delay time	<50> t _{DKBH}	5	25	ns
HLD \overline{RQ} setup time (vs. CLKOUT ↓)	<51> t _{SHQK}	7		ns
CLKOUT ↓ → HLD \overline{AK} delay time	<52> t _{DKHA}	5	25	ns
CLKOUT ↑ → \overline{DMAAK} delay time	<53> t _{DKHDA}	5	25	ns
CLKOUT ↓ → \overline{DMAAK} delay time (cascade mode)	<54> t _{DKLDA}	5	45	ns
\overline{WR} low-level width (DMA cycle)	DMA extended write	<55> t _{WW1}	2t _{CYK} -15	ns
	DMA normal write	<56> t _{WW2}	t _{CYK} -15	ns
\overline{RD} ↓, \overline{WR} ↓ delay time (vs. \overline{DMAAK} ↓)	<57> t _{DDARW}	t _{KKH} -10		ns
\overline{DMAAK} ↑ delay time (vs. \overline{RD} ↑)	<58> t _{DRHDAH}	t _{KKL} -10		ns
\overline{RD} ↑ delay time (vs. \overline{WR} ↑)	<59> t _{DWHRH}	3		ns
\overline{TC} output delay time (vs. CLKOUT ↑)	<60> t _{DKTCL}		25	ns
\overline{TC} OFF delay time (vs. CLKOUT ↑)	<61> t _{DKTCF}		25	ns
\overline{TC} low-level width	<62> t _{TCTCL}	t _{CYK} -10		ns
\overline{TC} pull-up delay time (vs. CLKOUT ↑)	<63> t _{DKTCH}		Note 3	ns
\overline{END} setup time (vs. CLKOUT ↑)	<64> t _{SEDK}	20		ns
\overline{END} low-level width	<65> t _{EDEDL}	40		ns
DMARQ setup time (vs. CLKOUT ↑)	<66> t _{SDQK}	10		ns
INTP _n low-level width	<67> t _{PIPL}	60		ns
RxD setup time (vs. SCU internal clock ↓)	<68> t _{SRX}	500		ns
RxD hold time (vs. SCU internal clock ↓)	<69> t _{HRX}	500		ns
CLKOUT ↓ → SRD \overline{Y} delay time	<70> t _{DKSR}		100	ns

- Notes**
1. \overline{MWR} and \overline{IOWR} signals in DMA cycle
 2. \overline{MWR} and \overline{IOWR} signals in \overline{BUFEN} , $\overline{BUF\overline{R}/W}$, \overline{INTAK} , \overline{REFRQ} , and CPU cycles
 3. t_{KKH} + 2t_{CYK} - 5 (reference value when a 1.1-kΩ pull-up resistor is connected)

(2) μPD70208H, 70216H-20 (T_A = -40 to +85 °C, V_{DD} = 5 V ±5%) (3/3)

Output Pin Load Capacitance: C_L = 100 pF

Parameter	Symbol	μPD70208H-20 μPD70216H-20		Unit
		MIN.	MAX.	
TOUT1 ↓ → TxD delay time	<71> t _{DTX}		200	ns
TCTL2 setup time (vs. CLKOUT ↓)	<72> t _{SGK}	40		ns
TCTL2 setup time (vs. TCLK ↑)	<73> t _{SGTK}	40		ns
TCTL2 hold time (vs. CLKOUT ↓)	<74> t _{HKG}	80		ns
TCTL2 hold time (vs. TCLK ↑)	<75> t _{HTKG}	40		ns
TCTL2 high-level width	<76> t _{GGH}	40		ns
TCTL2 low-level width	<77> t _{GGL}	40		ns
TOUT output delay time (vs. CLKOUT ↓)	<78> t _{DKTO}		150	ns
TOUT output delay time (vs. TCLK ↓)	<79> t _{DTKTO}		100	ns
TOUT output delay time (vs. TCTL2 ↓)	<80> t _{DGTO}		90	ns
TCLK rise time	<81> t _{TKR}		25	ns
TCLK fall time	<82> t _{TKF}		25	ns
TCLK high-level width	<83> t _{TKTKH}	23		ns
TCLK low-level width	<84> t _{TKTKL}	23		ns
TCLK cycle	<85> t _{CYK}	50	DC	ns
Access interval ^{Note 1}	<86> t _{AI}	2t _{CYK} -15		ns
REFRQ ↑ delay time (vs. MRD ↑) ^{Note 2}	<87> t _{DRQHRH}	t _{KKL} -10		ns
RESET pulse width ^{Note 3}	<88> t _{WRESL}	4t _{CYK}		ns

- Notes**
1. This rating is to guarantee the read/write recovery time for the I/O device.
 2. This rating is to guarantee that REFRQ ↑ is always behind MRD ↑, and guaranteed only when the EREF bit of the STCL register is 0.
 3. When using internal clock generator by connecting a resonator to the X1 and X2 pins, the oscillation stabilization time must be added at power-ON. Because the oscillation stabilization time varies depending on the characteristics of the resonator and oscillator used, evaluate the oscillation stabilization time with the resonator and oscillator actually used.

RECOMMENDED OSCILLATOR

The clock input circuits (1) and (2) shown below are recommended.

- (1) **Ceramic resonator connection** ($T_A = -40$ to $+85$ °C, $V_{DD} = 5$ V $\pm 10\%$ (μ PD70208H, 70216H-10/12/16), $V_{DD} = 5$ V $\pm 5\%$ (μ PD70208H, 70216H-20))

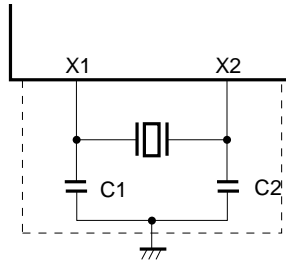

- Cautions**
1. The oscillator should be as close as possible to the X1 and X2 pins.
 2. No other signal lines should pass through the area enclosed in dashed line.
 3. For matching between V40HL, V50HL and resonator, the efficient evaluation should be carried out.
 4. The values of the oscillator constants C1 and C2 depend on the characteristics of the resonator used. Evaluate them with the resonator actually used.

Manufacturer	Frequency (f _{xx}) [MHz]	Product Name	Recommended Constant	
			C1 [pF]	C2 [pF]
Murata Mfg. Co., Ltd.	40	CSA40.00MXZ040	3	3
	32	CSA32.00MXZ040	5	5
	25	CSA25.00MXZ040	5	5
	20	CSA20.00MXZ040	10	10
TDK Corp.	32	FCR32.0M2G	5	5
	25	FCR25.0M2G	5	5
	20	FCR20.0M2G	10	10

(2) **External clock input**

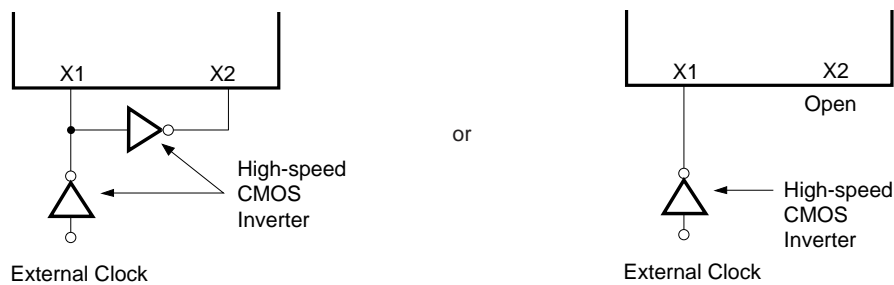

Caution The high-speed CMOS inverter should be as close as possible to the X1 and X2 pins.

16.2 AT 3 V OPERATION

OPERATING RANGE

	E, P, X, M Masks	Others
μPD70208H, 70216H-10/12/16	V _{DD} = 3 V ±10%	
μPD70208H, 70216H-20	—	V _{DD} = 3 V ±10%

ABSOLUTE MAXIMUM RATINGS (T_A = 25 °C)

Parameter	Symbol	Test Conditions	Rating	Unit
Supply voltage	V _{DD}		-0.5 to +7.0	V
Input voltage	V _I	V _{DD} = 3 V ±10%	-0.5 to V _{DD} + 0.3	V
Clock input voltage	V _K		-0.5 to V _{DD} + 1.0	V
Output voltage	V _O		-0.5 to V _{DD} + 0.3	V
Operating ambient temperature	T _A		-40 to +85	°C
Storage temperature	T _{stg}		-65 to +150	°C

- Cautions**
1. Do not directly connect the output pins of two or more IC products and do not directly connect the output pins to V_{DD} or V_{CC} and GND. However, open-drain pins or open-collector pins may be connected directly. Moreover, an external circuit whose timing is designed to avoid output collision can be connected to pins that go into a high-impedance state.
 2. If even one of the above parameters exceeds the absolute maximum rating even momentarily, the quality of the program may be degraded. Absolute maximum ratings, therefore, are the values exceeding which the product may be physically damaged. Use the program keeping all the parameters within these rated values.

The standards and conditions shown in DC and AC Characteristics below specify the range within which the normal operation of the product is guaranteed.

DC CHARACTERISTICS (T_A = -40 to +85 °C, V_{DD} = 3 V ±10%)

Parameter	Symbol	Test Conditions	MIN.	TYP.	MAX.	Unit	
Input voltage high	V _{IH}	Except RESE \bar{T}	0.7 V _{DD}		V _{DD} +0.3	V	
		RESE \bar{T}	0.8 V _{DD}		V _{DD} +0.3		
Input voltage low	V _{IL}	Except RESE \bar{T}	-0.5		0.2 V _{DD}	V	
		RESE \bar{T}					
Clock input voltage high	V _{KH}		0.8 V _{DD}		V _{DD} +0.5	V	
Clock input voltage low	V _{KL}		-0.5		0.2 V _{DD}	V	
Output voltage high	V _{OH}	I _{OH} = -2.5 mA	0.7 V _{DD}			V	
		I _{OH} = -100 μA	V _{DD} - 0.4				
Output voltage low	V _{OL}	Except EN $\bar{D}/\bar{T}C$: I _{OL} = 2.5 mA			0.4	V	
		EN $\bar{D}/\bar{T}C$: I _{OL} = 5.0 mA					
Input leak current high	I _{LIH}	V _I = V _{DD}			10	μA	
Input leak current low	I _{LIL}	V _I = 0 V : Except INTP			-10	μA	
INTP input current low	I _{L IPL}	V _I = 0 V : INTP input			-300	μA	
Output leak current high	I _{LOH}	V _O = V _{DD}			10	μA	
Output leak current low	I _{LOL}	V _O = 0 V			-10	μA	
Latch leak current high	I _{LLH}	V _I = 3.0 V	-50		-300	μA	
Latch leak current low	I _{LLL}	V _I = 0.8 V	50		300	μA	
Latch inversion current (L → H)	I _{L LH}				400	μA	
Latch inversion current (H → L)	I _{L LL}				-400	μA	
Supply current ^{Note}	I _{DD}	E, P, X, M masks	On Operation		3.0 f _x	5.5 f _x	mA
			On standby (HALT)		0.9 f _x	1.5 f _x	
			On standby (STOP)			30	
	Others	On Operation		2.5 f _x	4.0 f _x	mA	
		On standby (HALT)		0.9 f _x	1.5 f _x		
		On standby (STOP)			30		μA

Note The unit of constant values (0.9, 1.5, 2.5, 3.0, 4.0 and 5.5) is mA/MHz.

CAPACITANCE (T_A = 25 °C, V_{DD} = 0 V)

Parameter	Symbol	Test Conditions	MIN.	TYP.	MAX.	Unit
Input capacitance	C _I	f _c = 1 MHz			10	pF
Input/output capacitance	C _{IO}	0 V other than test pin.			15	pF

AC CHARACTERISTICS

(1) μPD70208H, 70216H-10/12/16 (T_A = -40 to +85 °C, V_{DD} = 3 V ±10%) (1/3)

Output Pin Load Capacitance: C_L = 100 pF

Parameter	Symbol	μPD70208H-10 μPD70216H-10		μPD70208H-12 μPD70216H-12		μPD70208H-16 μPD70216H-16		Unit	
		MIN.	MAX.	MIN.	MAX.	MIN.	MAX.		
		External clock input cycle	<1>	t _{CYX}	100	DC	83		DC
External clock input high-level width (V _{KH} =0.8 V _{DD})	<2>	t _{BXH}	40		30		20		ns
External clock input low-level width (V _{KL} =0.2 V _{DD})	<3>	t _{BXL}	40		30		20		ns
External clock input rise time (0.2 V _{DD} →0.8 V _{DD})	<4>	t _{XR}		10		10		10	ns
External clock input fall time (0.8 V _{DD} →0.2 V _{DD})	<5>	t _{XF}		10		10		10	ns
Clock output cycle	<6>	t _{CYK}	200	DC	166	DC	125	DC	ns
Clock output high-level width (V _{OH} =0.7 V _{DD})	<7>	t _{KKH}	0.5t _{CYK} -7		0.5t _{CYK} -7		0.5t _{CYK} -7		ns
Clock output low-level width (V _{OL} =0.2 V _{DD})	<8>	t _{KKL}	0.5t _{CYK} -7		0.5t _{CYK} -7		0.5t _{CYK} -7		ns
Clock output rise time (0.2 V _{DD} →0.7 V _{DD})	<9>	t _{KR}		7		7		7	ns
Clock output fall time (0.7 V _{DD} →0.2 V _{DD})	<10>	t _{KF}		7		7		7	ns
CLKOUT delay time (vs. external clock)	<11>	t _{DXK}		75		65		55	ns
Input rise time (except external clock) (0.2 V _{DD} →0.7 V _{DD})	<12>	t _{IR}		20		20		20	ns
Input fall time (except external clock) (0.7 V _{DD} →0.2 V _{DD})	<13>	t _{IF}		12		12		12	ns
Output rise time (except CLKOUT) (0.2 V _{DD} →0.7 V _{DD})	<14>	t _{OR}		20		20		20	ns
Output fall time (except CLKOUT) (0.7 V _{DD} →0.2 V _{DD})	<15>	t _{OF}		12		12		12	ns
RESET setup time (vs. CLKOUT↓) ^{Note 1}	<16>	t _{SRESK}	25		25		25		ns
RESET hold time (vs. CLKOUT↓) ^{Note 1}	<17>	t _{HKRES}	35		35		35		ns
RESOUT output delay time (vs. CLKOUT↓)	<18>	t _{DKRES}	5	80	5	70	5	60	ns
READY inactive setup time (vs. CLKOUT↑)	<19>	t _{SRYLK}	20		20		15		ns
READY inactive hold time (vs. CLKOUT↑)	<20>	t _{HKRYL}	30		30		25		ns
READY active setup time (vs. CLKOUT↑)	<21>	t _{SRYHK}	20		20		15		ns
READY active hold time (vs. CLKOUT↑)	<22>	t _{HKRYH}	30		30		25		ns
NMI setup time (vs. CLKOUT↑)	<23>	t _{SNMIK}	15		15		15		ns
POLL setup time (vs. CLKOUT↑)	<24>	t _{SPOLK}	20		20		20		ns
Data setup time (vs. CLKOUT↓)	<25>	t _{SDK}	20		20		15		ns
Data hold time (vs. CLKOUT↓)	<26>	t _{HKD}	5		5		5		ns
CLKOUT → address delay time ^{Note 2}	<27>	t _{DKA}	5	75	5	65	5	55	ns
★ CLKOUT → address hold time	<28>	t _{HKA}	5		5		5		ns
CLKOUT↓ → PS delay time	<29>	t _{DKP}	5	80	5	70	5	60	ns
CLKOUT↓ → PS float delay time	<30>	t _{FKP}	5	80	5	70	5	60	ns
Address setup time (vs. ASTB↓)	<31>	t _{SAST}	t _{KKL} -30		t _{KKL} -30		t _{KKL} -30		ns
★ CLKOUT↓ → address float delay time ^{Note 3}	<32>	t _{FKA}	5	80	5	70	5	60	ns
CLKOUT↓ → ASTB↑ delay time	<33>	t _{DKSTH}	5	65	5	55	5	45	ns
CLKOUT↑ → ASTB↓ delay time	<34>	t _{DKSTL}	5	70	5	60	5	50	ns
ASTB high-level width	<35>	t _{STST}	t _{KKL} -10		t _{KKL} -10		t _{KKL} -10		ns

- Notes**
1. When reset with the minimum pulse width or when guaranteeing the RESOUT output timing.
 2. Specifications also corresponding to the QS0, QS1, and BUSLOCK signals, and A16/PS0-A19/PS3, \overline{UBE} , \overline{BUFEN} , $\overline{BUFR/W}$, \overline{MRD} , \overline{IORD} , \overline{MWR} , \overline{IOWR} , and BS0-BS2 signals at HLDRQ/HLDAK timing.
 3. Specifications also corresponding to the A16/PS0-A19/PS3, \overline{UBE} , \overline{BUFEN} , $\overline{BUFR/W}$, \overline{MRD} , \overline{IORD} , \overline{MWR} , \overline{IOWR} , and BS0-BS2 signals at HLDRQ/HLDAK timing.

(1) μPD70208H, 70216H-10/12/16 (T_A = -40 to +85 °C, V_{DD} = 3 V ±10%) (2/3)

Output Pin Load Capacitance: C_L = 100 pF

Parameter	Symbol	μPD70208H-10 μPD70216H-10		μPD70208H-12 μPD70216H-12		μPD70208H-16 μPD70216H-16		Unit
		MIN.	MAX.	MIN.	MAX.	MIN.	MAX.	
ASTB↓ → address hold time	<36> t _{HSTA}	t _{KKH} -30		t _{KKH} -30		t _{KKH} -20		ns
CLKOUT → control 1 ^{Note 1} delay time	<37> t _{DKCT1}	5	90	5	80	5	70	ns
CLKOUT → control 2 ^{Note 2} delay time	<38> t _{DKCT2}	5	80	5	70	5	60	ns
Address float → \overline{RD} ↓ delay time	<39> t _{DAFRL}	0		0		0		ns
CLKOUT↓ → \overline{RD} ↓ delay time	<40> t _{DKRL}	5	95	5	85	5	75	ns
CLKOUT↓ → \overline{RD} ↑ delay time	<41> t _{DKRH}	5	90	5	80	5	70	ns
\overline{RD} ↑ → address delay time	<42> t _{DRHA}	t _{CYK} -70		t _{CYK} -60		t _{CYK} -50		ns
\overline{RD} low-level width	<43> t _{RR}	2t _{CYK} -70		2t _{CYK} -60		2t _{CYK} -50		ns
\overline{BUFEN} ↑ → \overline{BUF} ↑/W delay time (read cycle)	<44> t _{DBECT}	t _{KKL} -30		t _{KKL} -30		t _{KKL} -20		ns
CLKOUT↓ → data output delay time	<45> t _{DKD}	5	80	5	70	5	60	ns
CLKOUT↓ → data float delay time	<46> t _{FKD}	5	80	5	70	5	60	ns
\overline{WR} low-level width	<47> t _{WW}	2t _{CYK} -50		2t _{CYK} -50		2t _{CYK} -40		ns
\overline{WR} ↑ → \overline{BUFEN} ↑ or \overline{BUF} ↑/W↓ (write cycle)	<48> t _{DWCT}	t _{KKL} -30		t _{KKL} -30		t _{KKL} -20		ns
CLKOUT↑ → BS↓ delay time	<49> t _{DKBL}	5	80	5	70	5	60	ns
CLKOUT↓ → BS↑ delay time	<50> t _{DKBH}	5	80	5	70	5	60	ns
HLD _{RQ} setup time (vs. CLKOUT↓)	<51> t _{SHQK}	25		25		20		ns
CLKOUT↓ → HLD _{AK} delay time	<52> t _{DKHA}	5	90	5	80	5	70	ns
CLKOUT↑ → \overline{DMAAK} delay time	<53> t _{DKHDA}	5	80	5	70	5	60	ns
CLKOUT↓ → \overline{DMAAK} delay time (cascade mode)	<54> t _{DKLDA}	5	110	5	100	5	90	ns
\overline{WR} low-level width (DMA cycle)	DMA extended write	<55> t _{WW1}	2t _{CYK} -50		2t _{CYK} -50		2t _{CYK} -40	ns
	DMA normal write	<56> t _{WW2}	t _{CYK} -50		t _{CYK} -50		t _{CYK} -40	ns
\overline{RD} ↓ \overline{WR} ↓ delay time (vs. \overline{DMAAK} ↓)	<57> t _{DDARW}	t _{KKH} -40		t _{KKH} -40		t _{KKH} -30		ns
\overline{DMAAK} ↑ delay time (vs. \overline{RD} ↑)	<58> t _{DRHDAH}	t _{KKL} -40		t _{KKL} -40		t _{KKL} -30		ns
\overline{RD} ↑ delay time (vs. \overline{WR} ↑)	<59> t _{DWHRH}	5		5		5		ns
\overline{TC} output delay time (vs. CLKOUT↑)	<60> t _{DKTCL}	5	80	5	70	5	60	ns
\overline{TC} OFF delay time (vs. CLKOUT↑)	<61> t _{DKTCF}	5	80	5	70	5	60	ns
\overline{TC} low-level width	<62> t _{TCTCL}	t _{CYK} -25		t _{CYK} -25		t _{CYK} -15		ns
\overline{TC} pull-up delay time (vs. CLKOUT↑)	<63> t _{DKTCH}		Note 3		Note 4		Note 4	ns
\overline{END} setup time (vs. CLKOUT↑)	<64> t _{SEDK}	45		40		35		ns
\overline{END} low-level width	<65> t _{EDEDL}	140		120		100		ns
DMARQ setup time (vs. CLKOUT↑)	<66> t _{SDQK}	45		40		35		ns
INTP _n low-level width	<67> t _{TIPL}	100		100		100		ns
RxD setup time (vs. SCU internal clock↓)	<68> t _{SRX}	1000		1000		1000		ns
RxD hold time (vs. SCU internal clock↓)	<69> t _{HRX}	1000		1000		1000		ns
CLKOUT↓ → \overline{SRDY} delay time	<70> t _{DKSR}		150		150		150	ns

- Notes**
1. \overline{MWR} and \overline{IOWR} signals in DMA cycle
 2. \overline{MWR} and \overline{IOWR} signals in CPU cycles and \overline{BUFEN} , \overline{BUF} ↑/W, \overline{INTAK} and \overline{REFRQ} signals.
 3. t_{KKH} + 2t_{CYK} - 20 (Reference value when a 1.1-kΩ pull-up resistor is connected)
 4. t_{KKH} + 2t_{CYK} - 10 (Reference value when a 1.1-kΩ pull-up resistor is connected)

(1) μPD70208H, 70216H-10/12/16 (T_A = -40 to +85 °C, V_{DD} = 3 V ±10%) (3/3)

Output Pin Load Capacitance: C_L = 100 pF

Parameter	Symbol	μPD70208H-10 μPD70216H-10		μPD70208H-12 μPD70216H-12		μPD70208H-16 μPD70216H-16		Unit
		MIN.	MAX.	MIN.	MAX.	MIN.	MAX.	
TOUT1↓→ TxD delay time	<71> t _{DTX}		500		500		500	ns
TCTL2 setup time (vs. CLKOUT↓)	<72> t _{SGK}	50		50		50		ns
TCTL2 setup time (vs. TCLK↑)	<73> t _{SGTK}	50		50		50		ns
TCTL2 hold time (vs. CLKOUT↓)	<74> t _{HKG}	100		100		100		ns
TCTL2 hold time (vs. TCLK↑)	<75> t _{HTKG}	50		50		50		ns
TCTL2 high-level width	<76> t _{GGH}	50		50		50		ns
TCTL2 low-level width	<77> t _{GGL}	50		50		50		ns
TOUT output delay time (vs. CLKOUT↓)	<78> t _{DKTO}		200		200		200	ns
TOUT output delay time (vs. TCLK↓)	<79> t _{DTKTO}		150		150		150	ns
TOUT output delay time (vs. TCTL2↓)	<80> t _{DGTO}		120		120		120	ns
TCLK rise time	<81> t _{TKR}		25		25		25	ns
TCLK fall time	<82> t _{TKF}		25		25		25	ns
TCLK high-level width	<83> t _{TKTKH}	60		55		50		ns
TCLK low-level width	<84> t _{TKTKL}	60		55		50		ns
TCLK cycle	<85> t _{CYTK}	200	DC	166	DC	125	DC	ns
Access interval ^{Note 1}	<86> t _{AI}	2t _{CYK} -70		2t _{CYK} -60		2t _{CYK} -50		ns
REFRQ↑ delay time (vs. MRD↑) ^{Note 2}	<87> t _{DRQHRH}	t _{KKL} -50		t _{KKL} -40		t _{KKL} -30		ns
RESET pulse width ^{Note 3}	<88> t _{WRESL}	4t _{CYK}		4t _{CYK}		4t _{CYK}		ns

Notes 1. Specification to guarantee read/write recovery time for I/O device.

2. Specification to guarantee that REFRQ↑ is always later than MRD↑.

Only guaranteed when the EREF bit of the SCTL register is 0.

3. When using internal clock generator by connecting a resonator to the X1 and X2 pins, the oscillation stabilization time must be added at power-ON. Because the oscillation stabilization time varies depending on the characteristics of the resonator and oscillator used, evaluate the oscillation stabilization time with the resonator and oscillator actually used.

(2) μPD70208H, 70216H-20 (T_A = -40 to +85 °C, V_{DD} = 3 V ±10%) (1/3)

Output Pin Load Capacitance: C_L = 100 pF

Parameter	Symbol		μPD70208H-20		Unit
			μPD70216H-20		
			MIN.	MAX.	
External clock input cycle	<1>	t _{CYX}	50	DC	ns
External clock input high-level width (V _{KH} =0.8 V _{DD})	<2>	t _{XH}	19		ns
External clock input low-level width (V _{KL} =0.2 V _{DD})	<3>	t _{XL}	19		ns
External clock input rise time (0.2 V _{DD} →0.8 V _{DD})	<4>	t _{XR}		5	ns
External clock input fall time (0.8 V _{DD} →0.2 V _{DD})	<5>	t _{XF}		5	ns
Clock output cycle	<6>	t _{CYK}	100	DC	ns
Clock output high-level width (V _{OH} =0.7 V _{DD})	<7>	t _{KKH}	0.5t _{CYK} -7		ns
Clock output low-level width (V _{OL} =0.2 V _{DD})	<8>	t _{KKL}	0.5t _{CYK} -7		ns
Clock output rise time (0.2 V _{DD} →0.7 V _{DD})	<9>	t _{KR}		7	ns
Clock output fall time (0.7 V _{DD} →0.2 V _{DD})	<10>	t _{KF}		7	ns
CLKOUT delay time (vs. external clock)	<11>	t _{DXK}		45	ns
Input rise time (except external clock) (0.2 V _{DD} →0.7 V _{DD})	<12>	t _{IR}		15	ns
Input fall time (except external clock) (0.7 V _{DD} →0.2 V _{DD})	<13>	t _{IF}		10	ns
Output rise time (except CLKOUT) (0.2 V _{DD} →0.7 V _{DD})	<14>	t _{OR}		15	ns
Output fall time (except CLKOUT) (0.7 V _{DD} →0.2 V _{DD})	<15>	t _{OF}		10	ns
RESET setup time (vs. CLKOUT↓) Note 1	<16>	t _{SRESK}	25		ns
RESET hold time (vs. CLKOUT↓) Note 1	<17>	t _{HKRES}	25		ns
RESOUT output delay time (vs. CLKOUT↓)	<18>	t _{DKRES}	5	50	ns
READY inactive setup time (vs. CLKOUT↑)	<19>	t _{SRYLK}	15		ns
READY inactive hold time (vs. CLKOUT↑)	<20>	t _{HKRYL}	20		ns
READY active setup time (vs. CLKOUT↑)	<21>	t _{SRYHK}	15		ns
READY active hold time (vs. CLKOUT↑)	<22>	t _{HKRYH}	20		ns
NMI setup time (vs. CLKOUT↑)	<23>	t _{SNMIK}	15		ns
POLL setup time (vs. CLKOUT↑)	<24>	t _{SPOLK}	20		ns
Data setup time (vs. CLKOUT↓)	<25>	t _{SDK}	15		ns
Data hold time (vs. CLKOUT↓)	<26>	t _{HKD}	5		ns
CLKOUT → address delay time Note 2	<27>	t _{DKA}	5	50	ns
★ CLKOUT → address hold time	<28>	t _{HKA}	5		ns
CLKOUT ↓ → PS delay time	<29>	t _{DKP}	5	50	ns
CLKOUT ↓ → PS float delay time	<30>	t _{FKP}	5	50	ns
Address setup time (vs. ASTB↓)	<31>	t _{SAST}	t _{KKL} -20		ns
CLKOUT ↓ → address float delay time Note 3	<32>	t _{FKA}	t _{HKA}	50	ns
CLKOUT ↓ → ASTB ↑ delay time	<33>	t _{DKSTH}		40	ns
CLKOUT ↑ → ASTB ↓ delay time	<34>	t _{DKSTL}		45	ns
ASTB high-level width	<35>	t _{TST}	t _{KKL} -10		ns

- Notes**
1. When reset with the minimum pulse width or when guaranteeing the RESOUT output timing.
 2. Specifications also corresponding to the QS0, QS1, and BUSLOCK signals, and A16/PS0-A19/PS3, UB \bar{E} , BUFEN, BUFR/W, MRD, IORD, MWR, IOWR, and BS0-BS2 signals at HLDRQ/HLDAK timing.
 3. Specifications also corresponding to the A16/PS0-A19/PS3, UB \bar{E} , BUFEN, BUFR/W, MRD, IORD, MWR, IOWR, and BS0-BS2 signals at HLDRQ/HLDAK timing.

(2) μPD70208H, 70216H-20 (T_A = -40 to +85 °C, V_{DD} = 3 V ±10%) (2/3)

Output Pin Load Capacitance: C_L = 100 pF

Parameter	Symbol	μPD70208H-20 μPD70216H-20		Unit
		MIN.	MAX.	
ASTB ↓ → address hold time	<36> t _{HSTA}	t _{KKH} -20		ns
CLKOUT → control 1 ^{Note 1} delay time	<37> t _{DKCT1}	5	60	ns
CLKOUT → control 2 ^{Note 2} delay time	<38> t _{DKCT2}	5	55	ns
Address float → \overline{RD} ↓ delay time	<39> t _{DAFRL}	0		ns
CLKOUT ↓ → \overline{RD} ↓ delay time	<40> t _{DKRL}	5	65	ns
CLKOUT ↓ → \overline{RD} ↑ delay time	<41> t _{DKRH}	5	60	ns
\overline{RD} ↑ → address delay time	<42> t _{DRHA}	t _{CYK} -40		ns
\overline{RD} low-level width	<43> t _{RR}	2t _{CYK} -40		ns
\overline{BUFEN} ↑ → $\overline{BUF\overline{R}/W}$ delay time (read cycle)	<44> t _{DBECT}	t _{KKL} -20		ns
CLKOUT ↓ → data output delay time	<45> t _{DKD}	5	55	ns
\overline{CLKOUT} ↓ → data float delay time	<46> t _{FKD}	5	55	ns
\overline{WR} low-level width	<47> t _{WW}	2t _{CYK} -40		ns
\overline{WR} ↑ → \overline{BUFEN} ↑ or $\overline{BUF\overline{R}/W}$ ↓ (write cycle)	<48> t _{DWCT}	t _{KKL} -20		ns
CLKOUT ↑ → BS ↓ delay time	<49> t _{DKBL}	5	55	ns
CLKOUT ↓ → BS ↑ delay time	<50> t _{DKBH}	5	55	ns
HLD \overline{RQ} setup time (vs. CLKOUT ↓)	<51> t _{SHQK}	15		ns
CLKOUT ↓ → HLD \overline{AK} delay time	<52> t _{DKHA}	5	60	ns
CLKOUT ↑ → \overline{DMAAK} delay time	<53> t _{DKHDA}	5	55	ns
CLKOUT ↓ → \overline{DMAAK} delay time (cascade mode)	<54> t _{DKLDA}	5	80	ns
\overline{WR} low-level width (DMA cycle)	DMA extended write	<55> t _{WW1}	2t _{CYK} -40	ns
	DMA normal write	<56> t _{WW2}	t _{CYK} -40	ns
\overline{RD} ↓, \overline{WR} ↓ delay time (vs. \overline{DMAAK} ↓)	<57> t _{DDARW}	t _{KKH} -30		ns
\overline{DMAAK} ↑ delay time (vs. \overline{RD} ↑)	<58> t _{DRHDAH}	t _{KKL} -30		ns
\overline{RD} ↑ delay time (vs. \overline{WR} ↑)	<59> t _{DWHRH}	3		ns
\overline{TC} output delay time (vs. CLKOUT ↑)	<60> t _{DKTCL}		55	ns
\overline{TC} OFF delay time (vs. CLKOUT ↑)	<61> t _{DKTCF}		55	ns
\overline{TC} low-level width	<62> t _{TCTCL}	t _{CYK} -15		ns
\overline{TC} pull-up delay time (vs. CLKOUT ↑)	<63> t _{DKTCH}		Note 3	ns
\overline{END} setup time (vs. CLKOUT ↑)	<64> t _{SEDK}	30		ns
END low-level width	<65> t _{EDEL}	80		ns
DMARQ setup time (vs. CLKOUT ↑)	<66> t _{SDQK}	30		ns
INTP _n low-level width	<67> t _{IPIPL}	80		ns
RxD setup time (vs. SCU internal clock ↓)	<68> t _{SRX}	500		ns
RxD hold time (vs. SCU internal clock ↓)	<69> t _{HRX}	500		ns
CLKOUT ↓ → \overline{SRDY} delay time	<70> t _{DKSR}		100	ns

- Notes**
1. \overline{MWR} and \overline{IOWR} signals in DMA cycle
 2. \overline{MWR} and \overline{IOWR} signals in CPU cycles and \overline{BUFEN} , $\overline{BUF\overline{R}/W}$, \overline{INTAK} and \overline{REFRQ} signals.
 3. t_{KKH} + 2t_{CYK} - 10 (reference value when a 1.1-kΩ pull-up resistor is connected)

(2) μPD70208H, 70216H-20 (T_A = -40 to +85 °C, V_{DD} = 3 V ±10%) (3/3)

Output Pin Load Capacitance: C_L = 100 pF

Parameter	Symbol	μPD70208H-20 μPD70216H-20		Unit
		MIN.	MAX.	
TOUT1 ↓ → TxD delay time	<71> t _{DTX}		200	ns
TCTL2 setup time (vs. CLKOUT ↓)	<72> t _{SGK}	40		ns
TCTL2 setup time (vs. TCLK ↑)	<73> t _{SGTK}	40		ns
TCTL2 hold time (vs. CLKOUT ↓)	<74> t _{HKG}	80		ns
TCTL2 hold time (vs. TCLK ↑)	<75> t _{HTKG}	40		ns
TCTL2 high-level width	<76> t _{GGH}	40		ns
TCTL2 low-level width	<77> t _{GGL}	40		ns
TOUT output delay time (vs. CLKOUT ↓)	<78> t _{DKTO}		150	ns
TOUT output delay time (vs. TCLK ↓)	<79> t _{DTKTO}		100	ns
TOUT output delay time (vs. TCTL2 ↓)	<80> t _{DGTO}		90	ns
TCLK rise time	<81> t _{TKR}		25	ns
TCLK fall time	<82> t _{TKF}		25	ns
TCLK high-level width	<83> t _{TKTKH}	45		ns
TCLK low-level width	<84> t _{TKTKL}	45		ns
TCLK cycle	<85> t _{CYK}	100	DC	ns
Access interval ^{Note 1}	<86> t _{AI}	2t _{CYK} -40		ns
REFRQ̄ ↑ delay time (vs. MRD̄ ↑) ^{Note 2}	<87> t _{DRQHRH}	t _{KKL} -30		ns
RESET̄ pulse width ^{Note 3}	<88> t _{WRESL}	4t _{CYK}		ns

- Notes**
1. This rating is to guarantee the read/write recovery time for the I/O device.
 2. This rating is to guarantee that REFRQ̄ ↑ is always behind MRD̄ ↑, and is guaranteed only when the EREF bit of the STCL register is 0.
 3. When using internal clock generator by connecting a resonator to the X1 and X2 pins, the oscillation stabilization time must be added at power-ON. Because the oscillation stabilization time varies depending on the characteristics of the resonator and oscillator used, evaluate the oscillation stabilization time with the resonator and oscillator actually used.

RECOMMENDED OSCILLATOR

The clock input circuits (1) and (2) shown below are recommended.

(1) Ceramic resonator connection ($T_A = -40$ to $+85$ °C, $V_{DD} = 3$ V $\pm 10\%$ ^{Note})

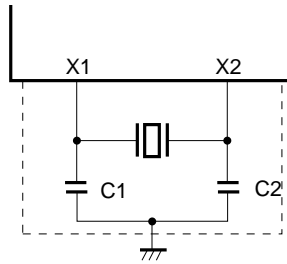

- Cautions**
1. The oscillator should be as close as possible to the X1 and X2 pins.
 2. No other signal lines should pass through the area enclosed in dashed line.
 3. V40HL, V50HL and resonator matching requires careful evaluation.
 4. The values of the oscillator constants C1 and C2 depend on the characteristics of the resonator used. Evaluate them with the resonator actually used.

Manufacturer	Frequency (f _{xx}) [MHz]	Product Name	Recommended Constant	
			C1 [pF]	C2 [pF]
Murata Mfg. Co., Ltd.	20	CSA20.00MXZ040 ^{Note}	10	10
		CSA16.00MXZ040	15	15
	16	CSA16.00MXW0C3	–	–
		CSA12.5MTZ	30	30
	12.5	CSA12.5MTW	–	–
		CSA10.0MTZ	30	30
TDK Corp.	20	FCR20.0M2G	10	10
		FCR16.0M2G	15	15
	10	FCR10.0MC	–	–

Note Use the CAS20.00MXZ040 within the range of $V_{DD} = 2.9$ to 3.3 V.

(2) External clock input

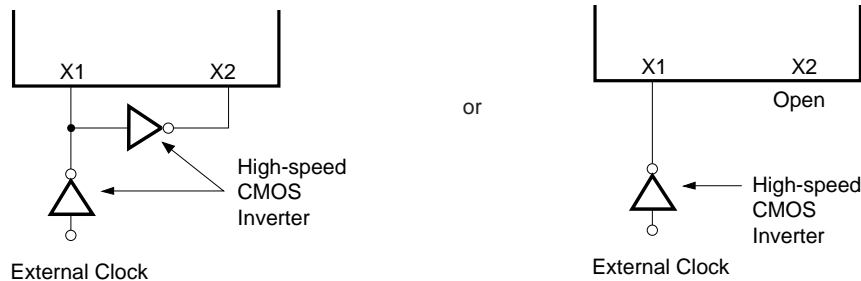

Caution The high-speed CMOS inverter should be as close as possible to the X1 and X2 pins.

AC Test Input Waveform (Except X1 and X2) (at 5 V operation)

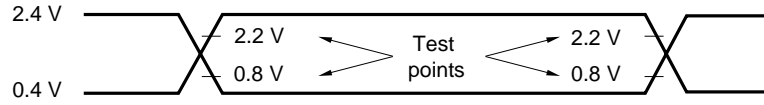

AC Test Output Test Points (at 5 V operation)

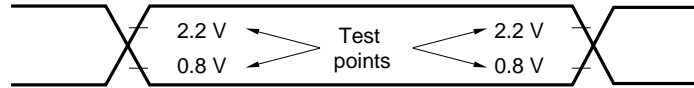

AC Test Input Waveform (Except X1 and X2) (at 3 V operation)

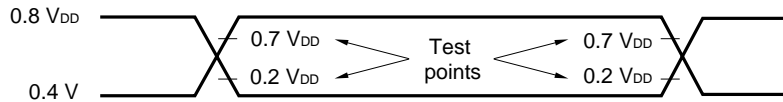

AC Test Output Waveform (at 3 V operation)

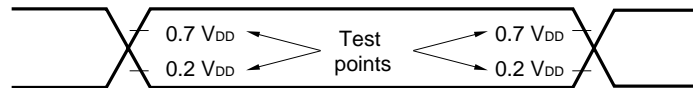

Load Conditions

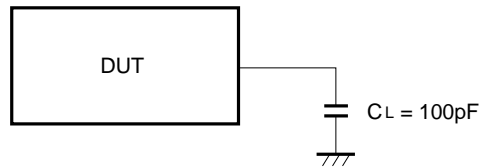

Caution If the load capacitance exceeds 100 pF due to the configuration of the circuit, the load capacitance of this device should be reduced to 100 pF or less by insertion of a buffer, etc.

Clock Timing

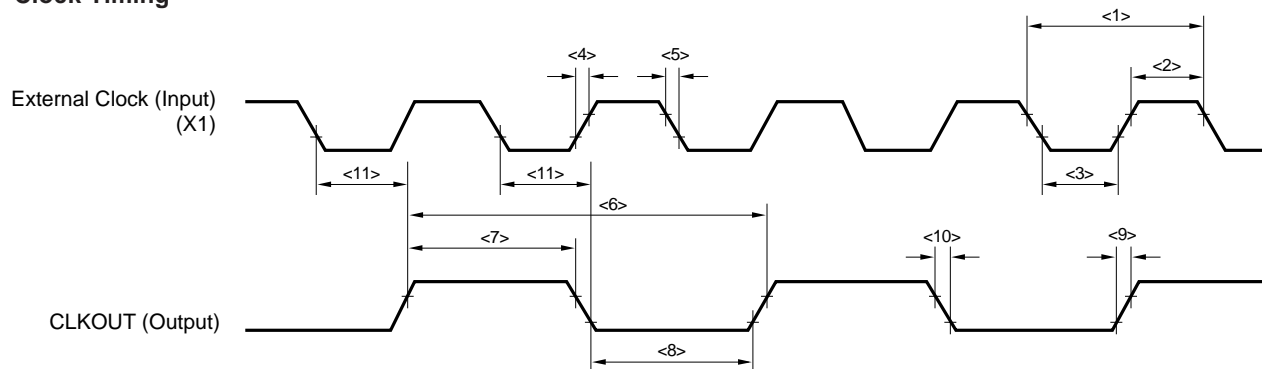

Reset Timing

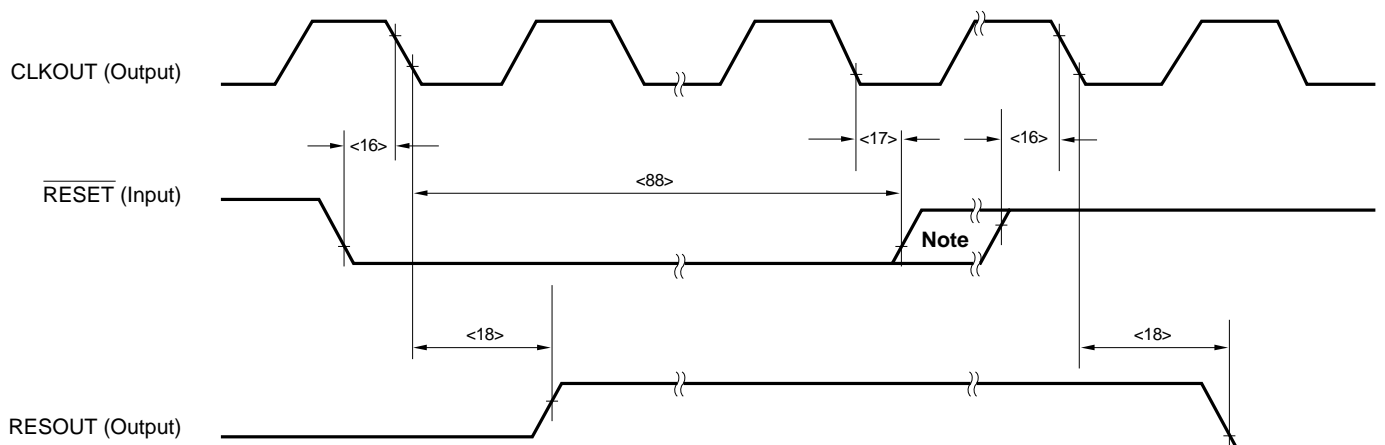

Ready Timing (1)

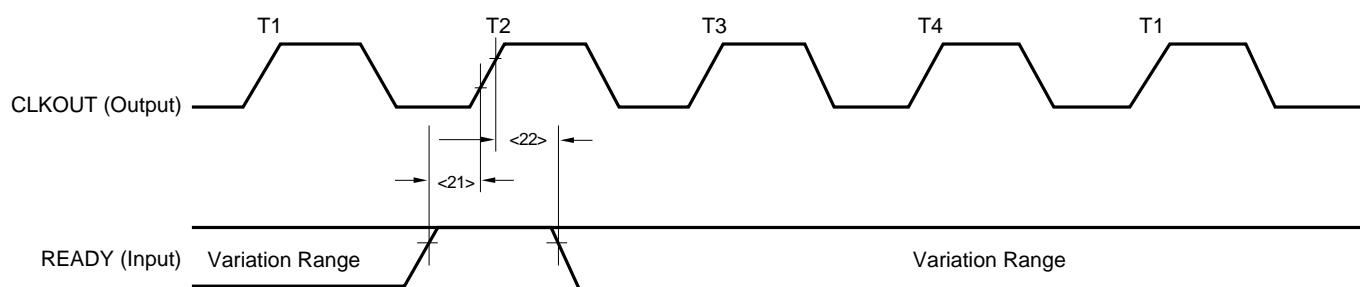

Ready Timing (2)

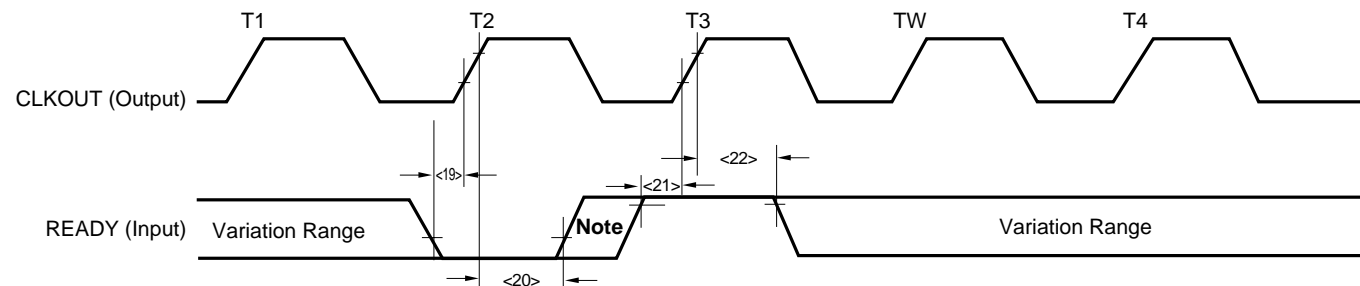

Note Variation range

Read Timing

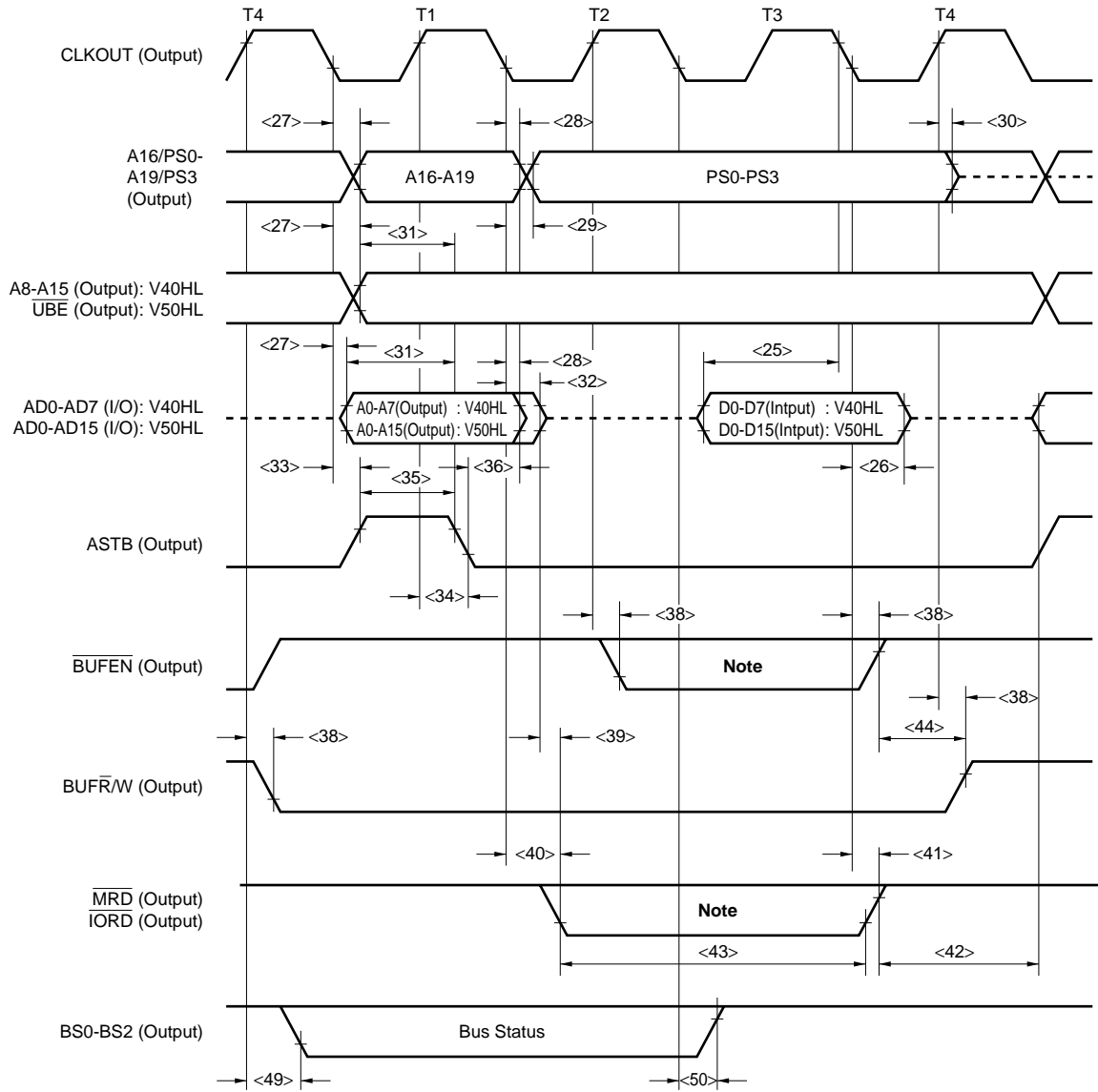

Note High-level signal is output in case of internal access.

Remark A dashed line indicates high impedance.

Write Timing

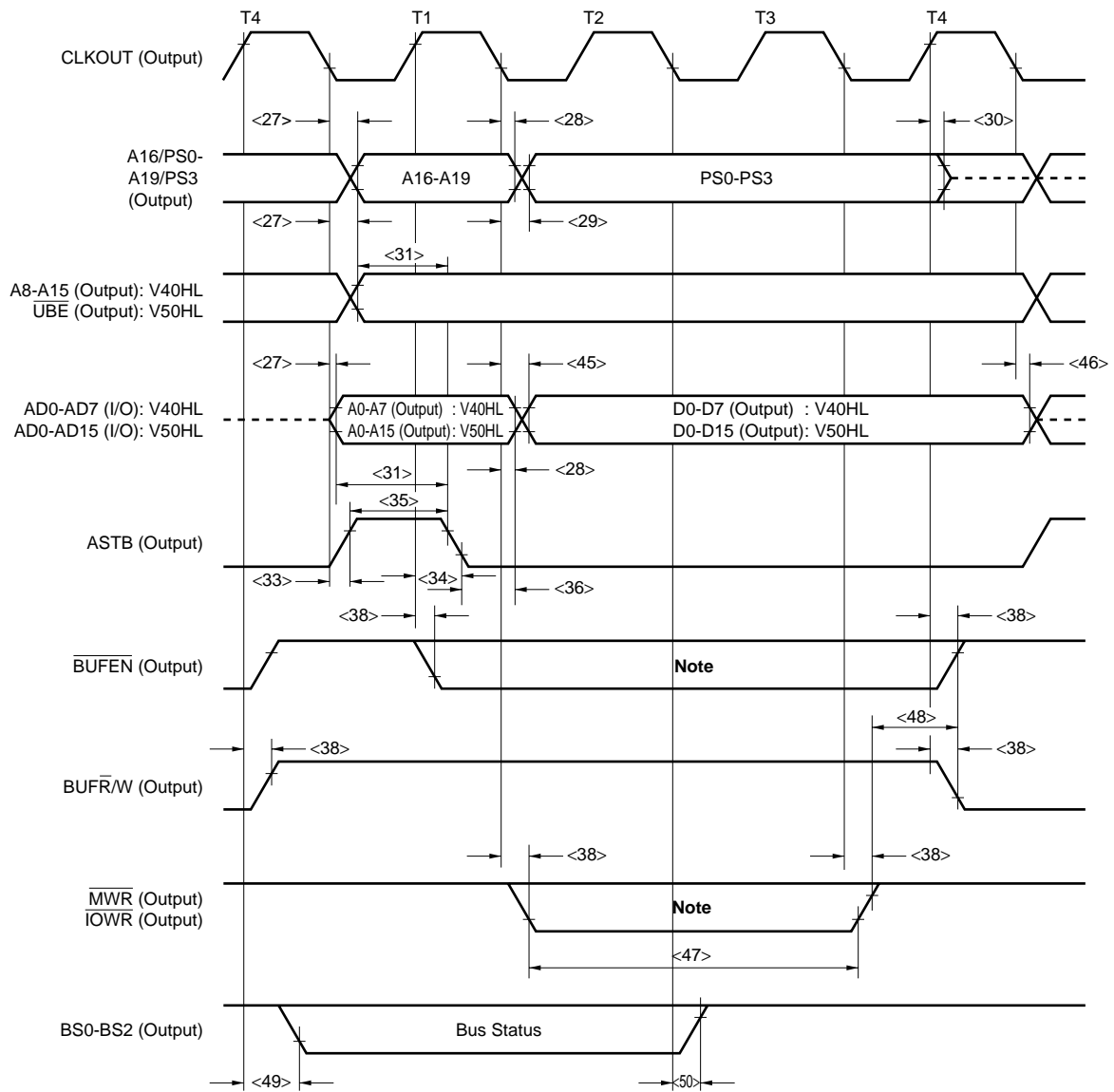

Note High-level signal is output in case of internal access.

Remark A dashed line indicates high impedance.

Status Timing

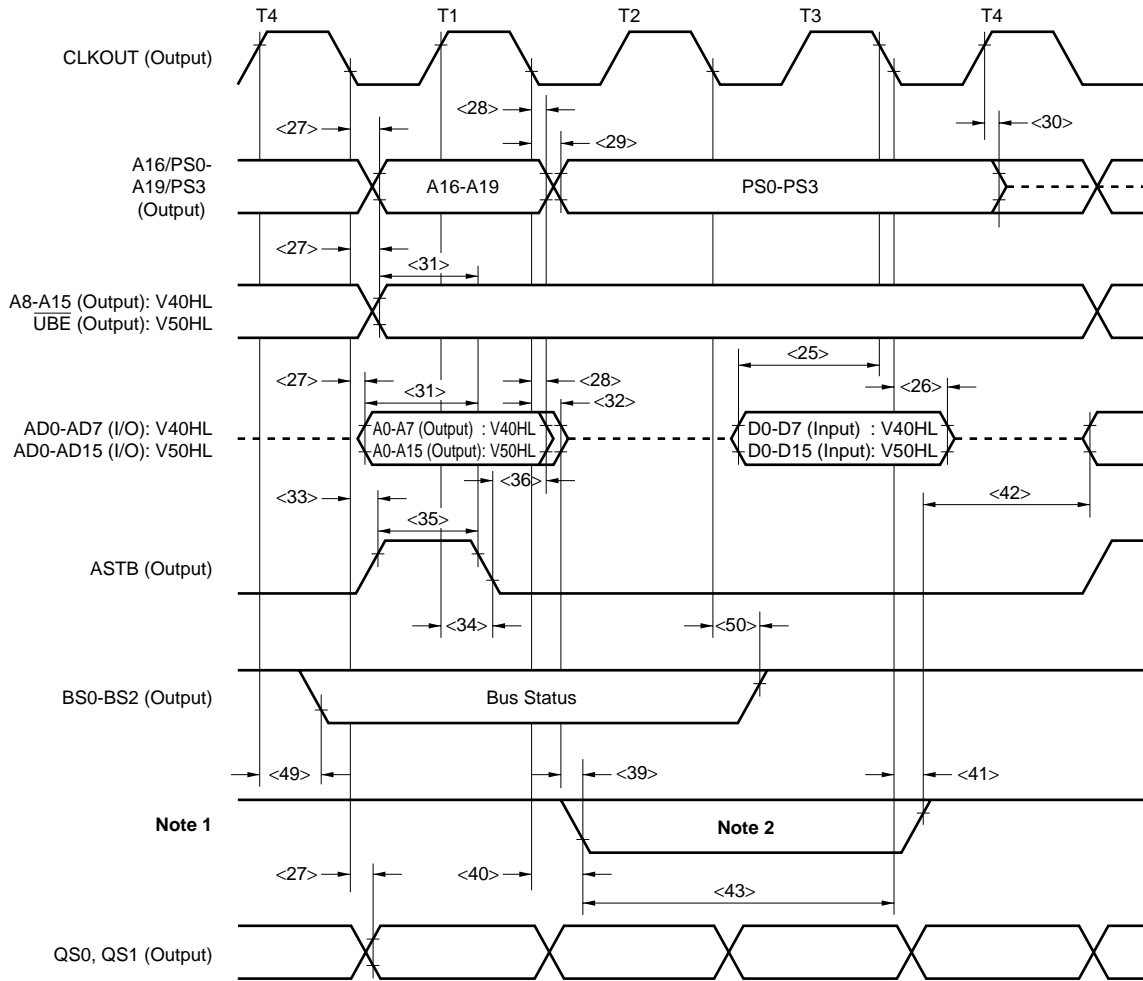

- Notes** 1. \overline{MRD} , \overline{IORD} , \overline{MWR} , \overline{IOWR} (all output)
 2. High-level signal is output in case of internal access.

Remark A dashed line indicates high impedance.

Interrupt Acknowledge Timing (V40HL)

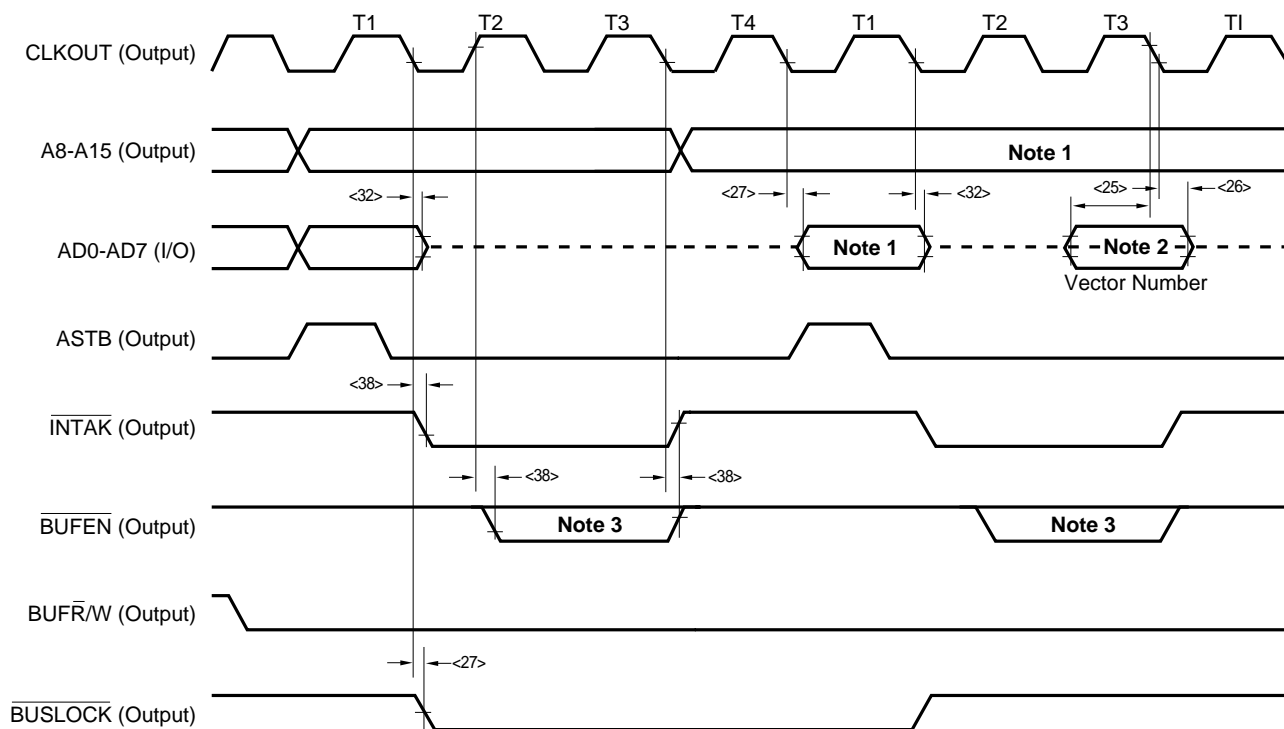

- Notes**
1. Slave address in case of interrupt from external μPD71059.
Invalid data in case of interrupt from internal ICU.
 2. Data read as vector address in case of interrupt from external μPD71059.
High impedance in case of interrupt from internal ICU.
 3. Low-level output in case of interrupt from external μPD71059.
High-level output in case of interrupt from internal ICU.

Remark A dashed line indicates high impedance.

Interrupt Acknowledge Timing (V50HL)

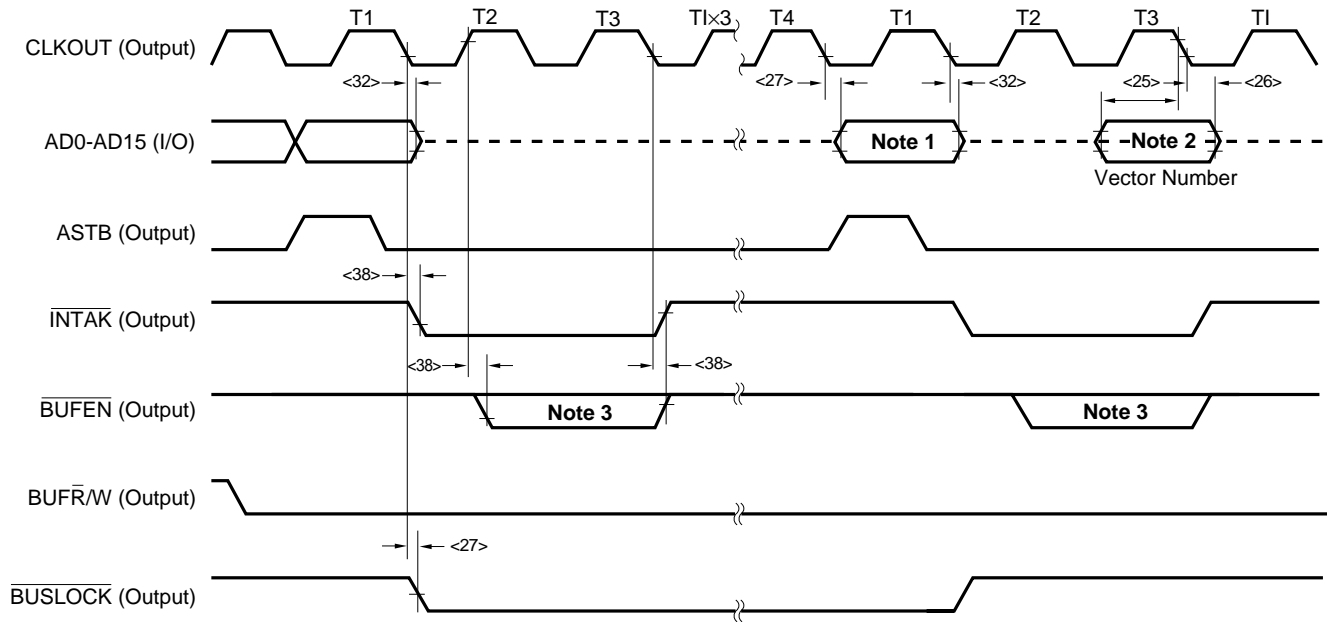

- Notes**
- 1.** Slave address in case of interrupt from external μPD71059.
Invalid data in case of interrupt from internal ICU.
- 2.** Data read as vector address in case of interrupt from external μPD71059.
High impedance in case of interrupt from internal ICU.
- 3.** Low-level output in case of interrupt from external μPD71059.
High-level output in case of interrupt from internal ICU.

Remark A dashed line indicates high impedance.

HLD RQ/HLDAK Timing (1)

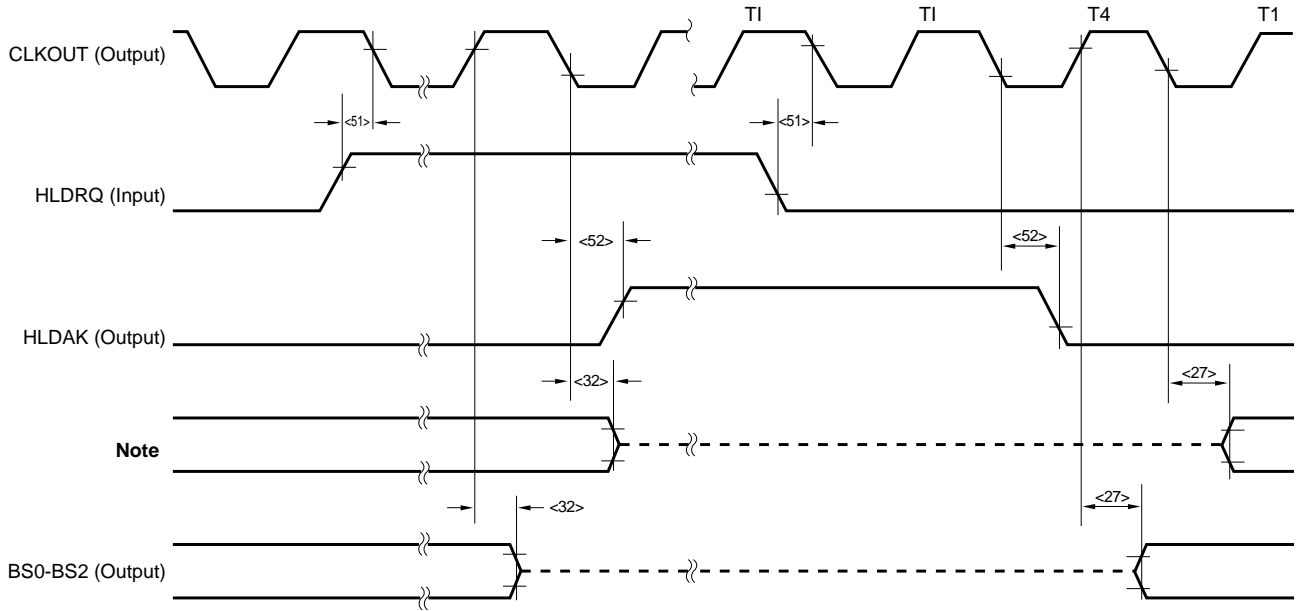

Note A16/PS0 to A19/PS3, \overline{UBE} , \overline{BUFEN} , $\overline{BUFR/W}$, \overline{MRD} , \overline{IORD} , \overline{MWR} , \overline{IOWR} (all output): V40HL, V50HL
 A8-A15 (output): V40HL AD0-AD7 (input/output): V40HL AD0-AD15 (input/output) V50HL

Remark A dashed line indicates high impedance.

HLD RQ/HLDAK Timing (2)

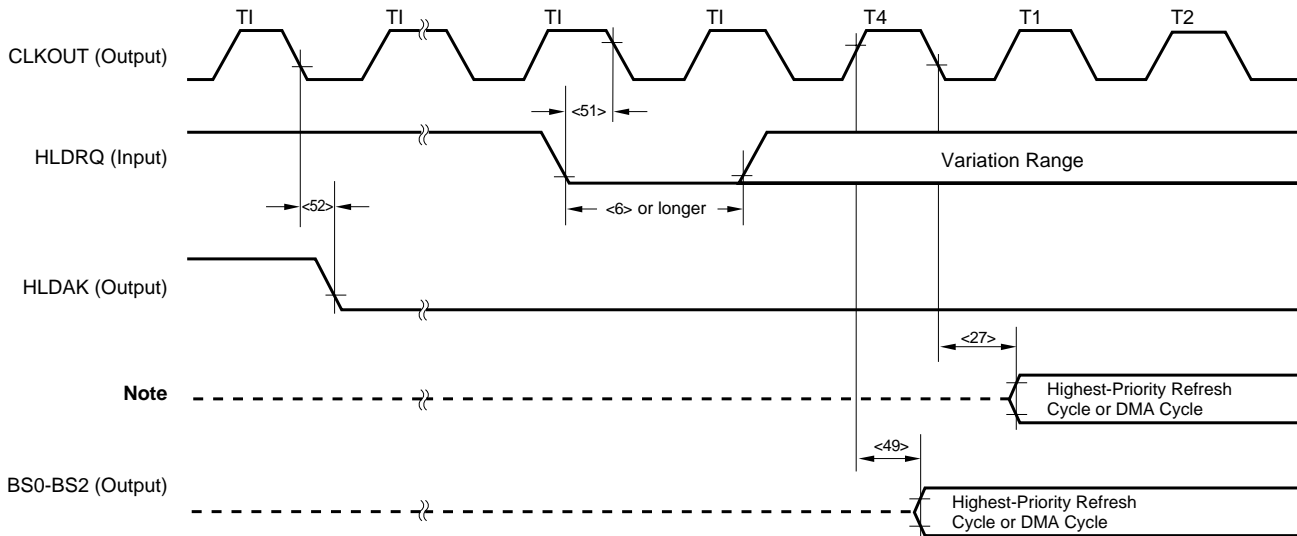

Note A16/PS0 to A19/PS3, \overline{UBE} , \overline{BUFEN} , $\overline{BUFR/W}$, \overline{MRD} , \overline{IORD} , \overline{MWR} , \overline{IOWR} (all output): V40HL, V50HL
 A8-A15 (output): V40HL AD0-AD7 (input/output): V40HL AD0-AD15 (input/output) V50HL

Remark A dashed line indicates high impedance.

POLL, NMI Input Timing

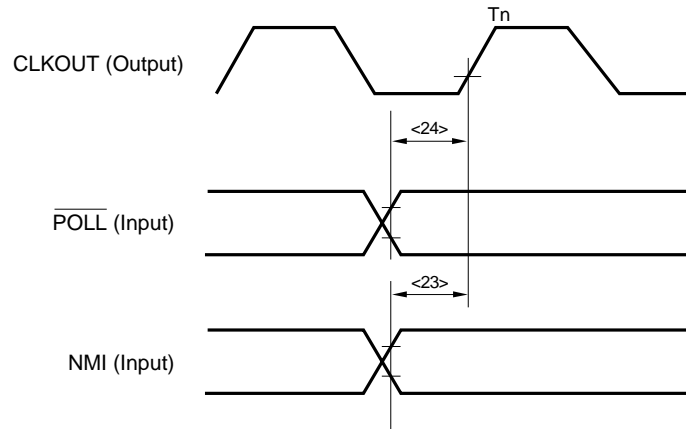

BUSLOCK Output Timing

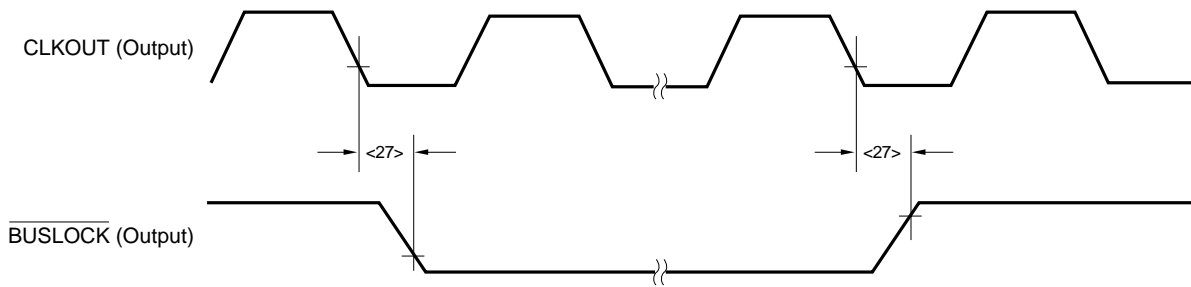

Access Interval

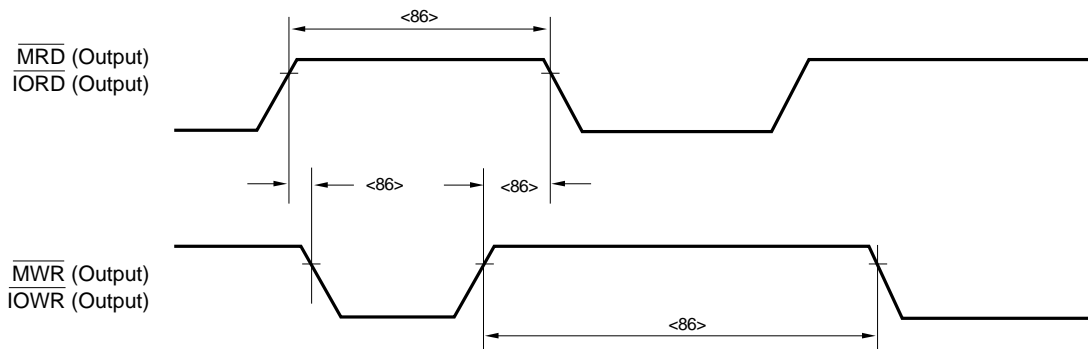

Refresh Timing (V40HL)

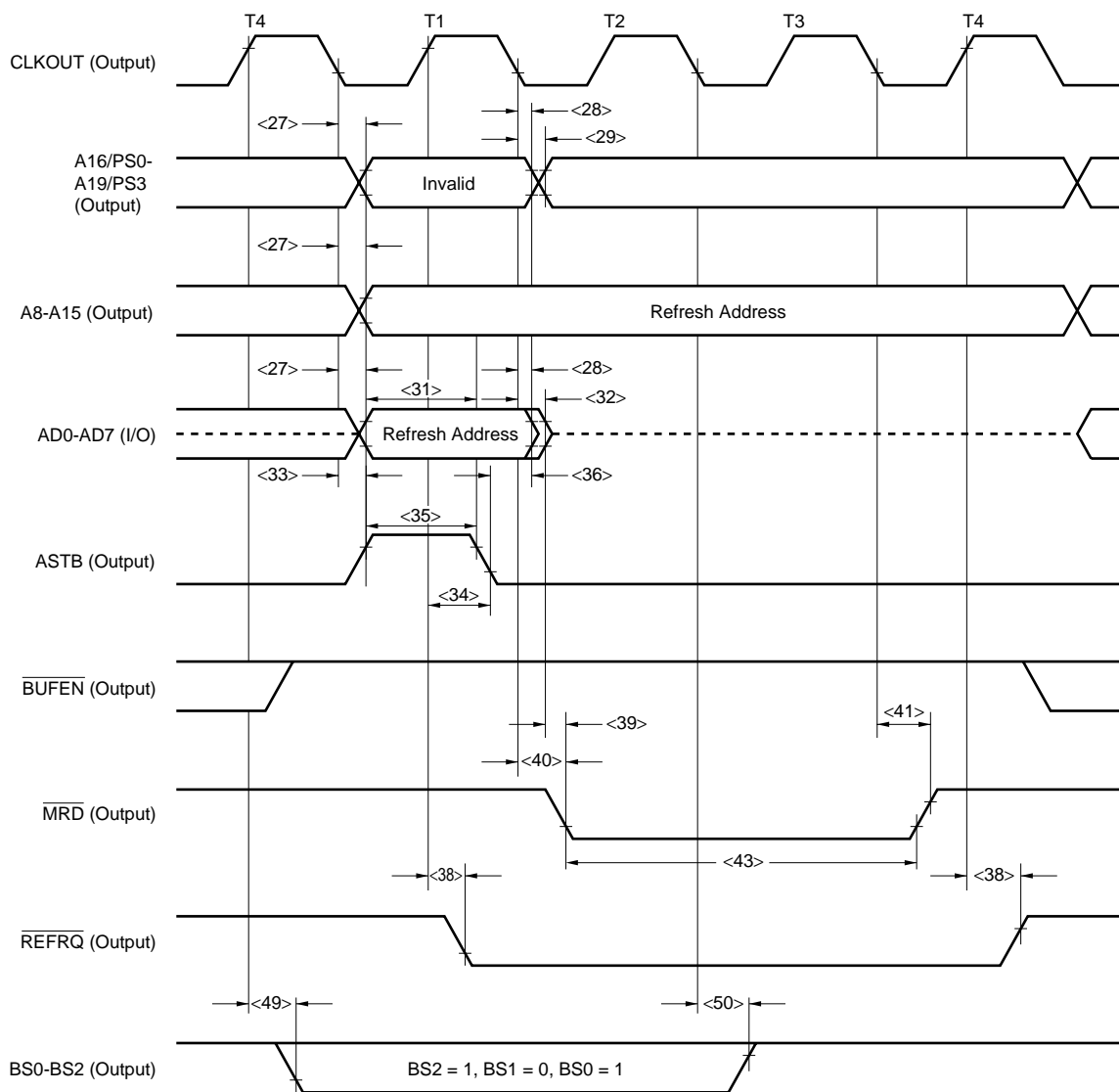

Remark A dashed line indicates high impedance.

Refresh Timing (V50HL)

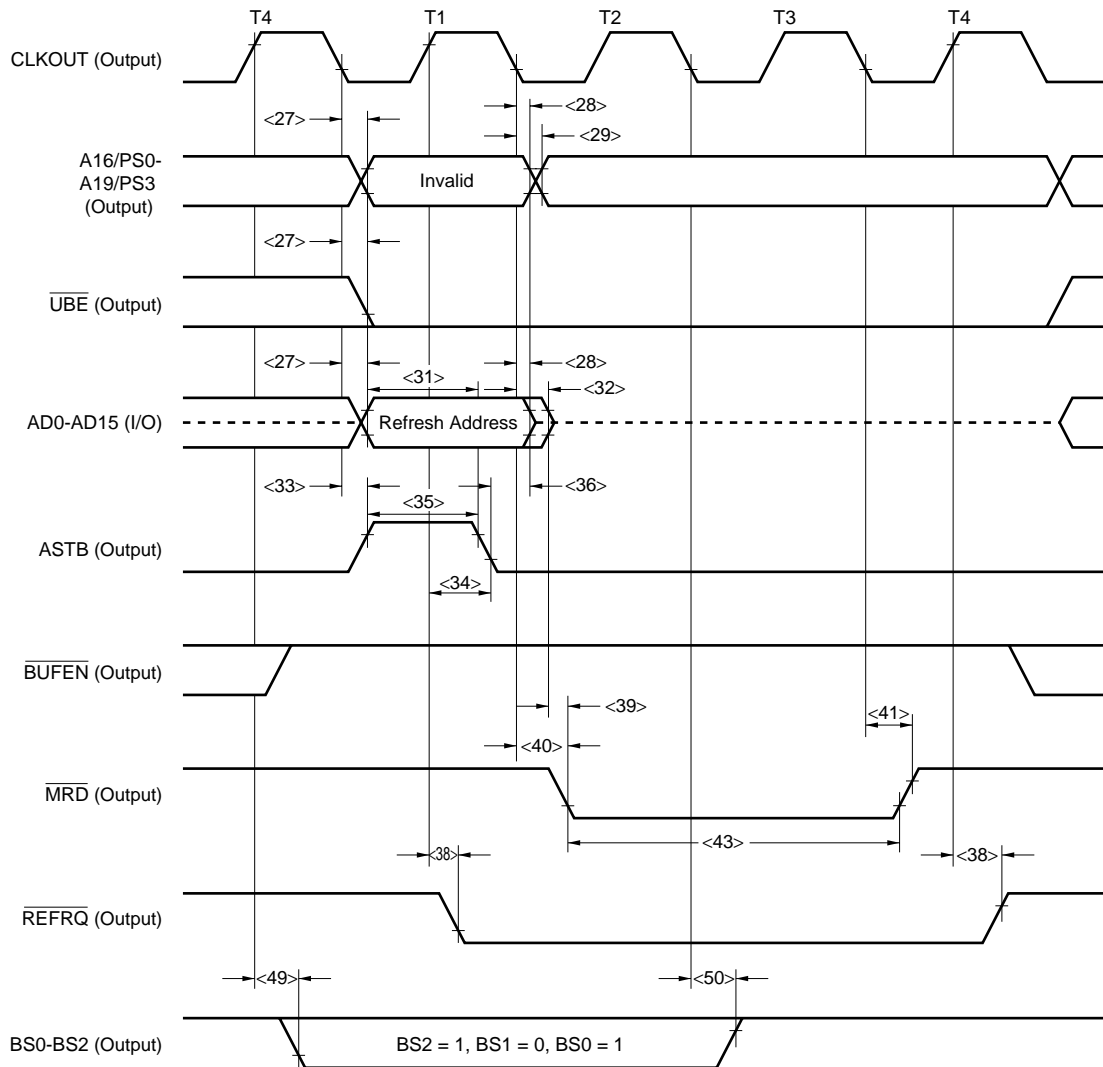

Remark A dashed line indicates high impedance.

TCU Timing (1)

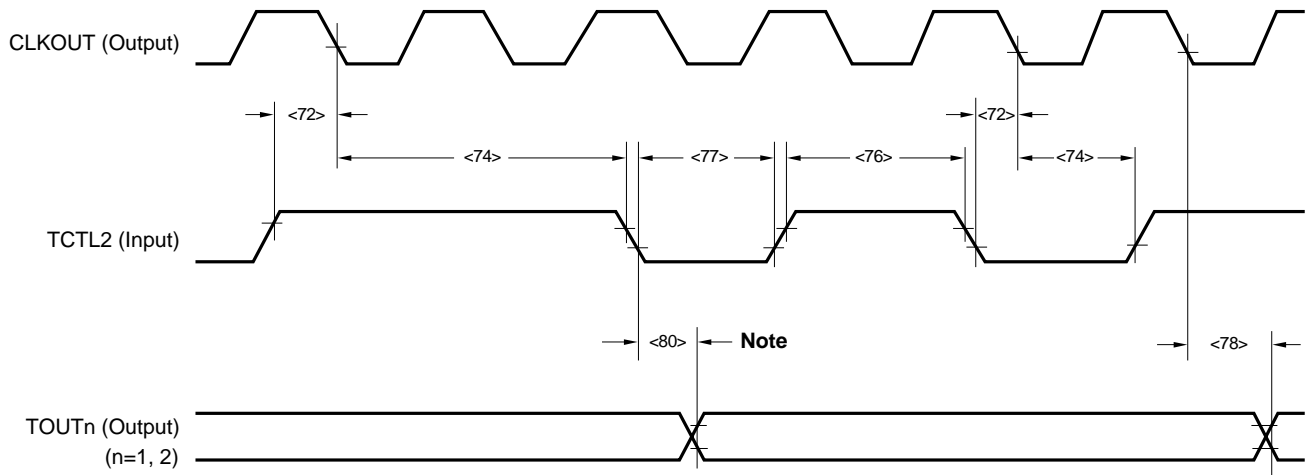

Note Applies to TOUT2 output.

TCU Timing (2)

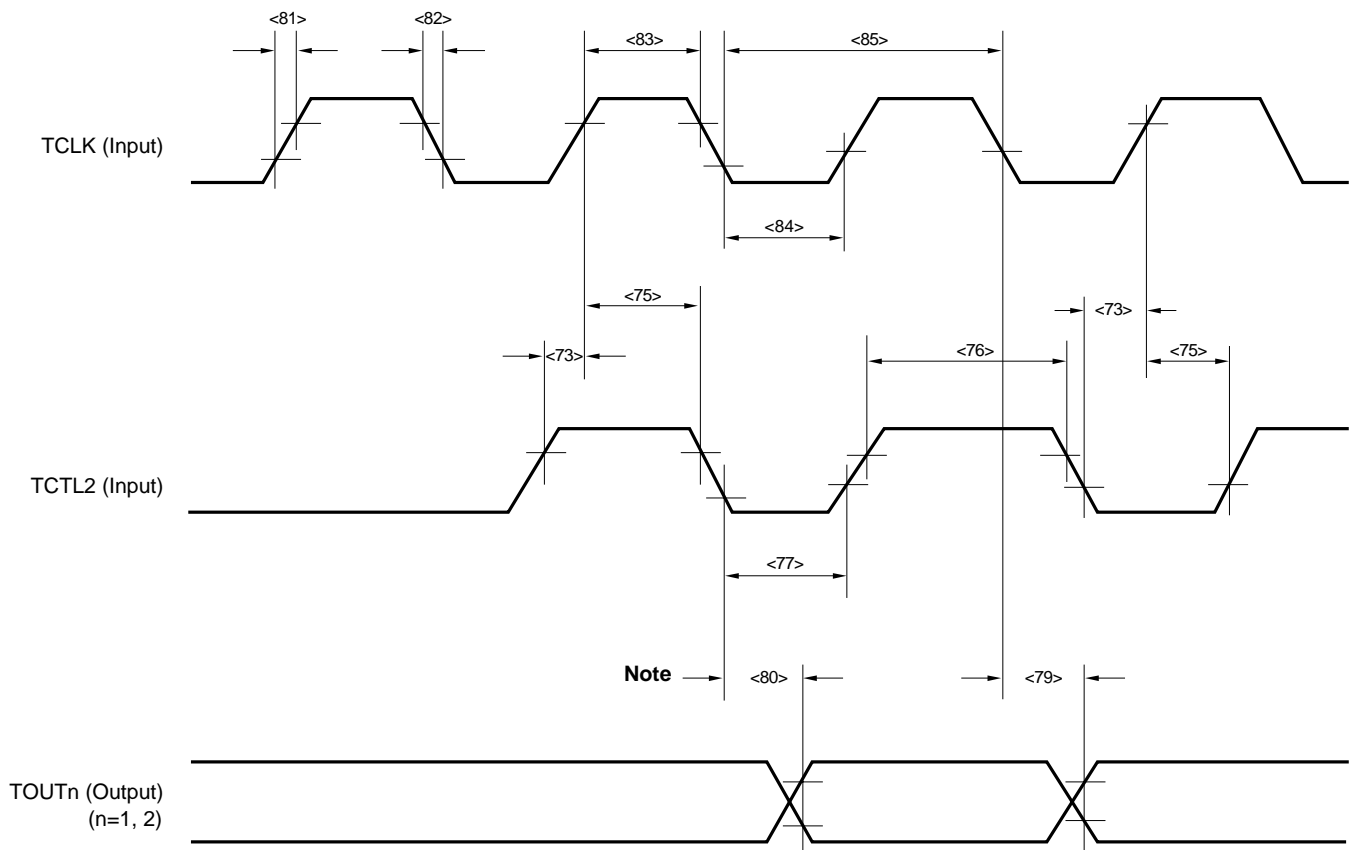

Note Applies to TOUT2 output.

SCU Timing

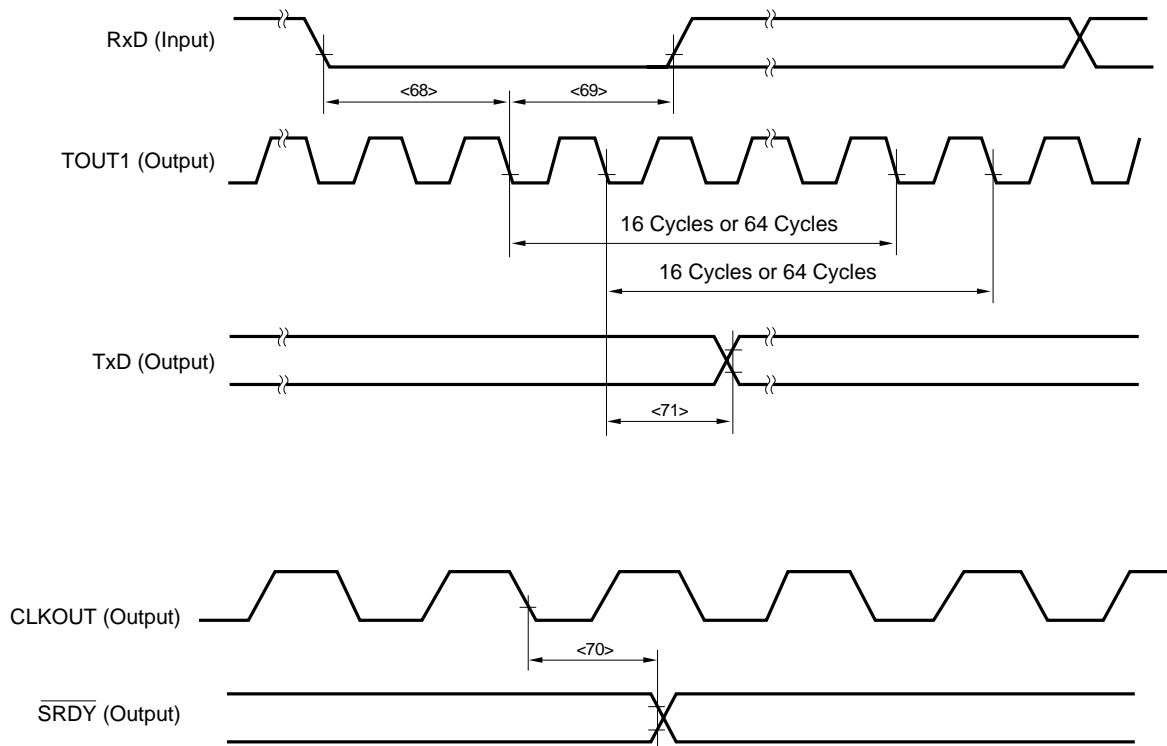

DMAU Timing (1)

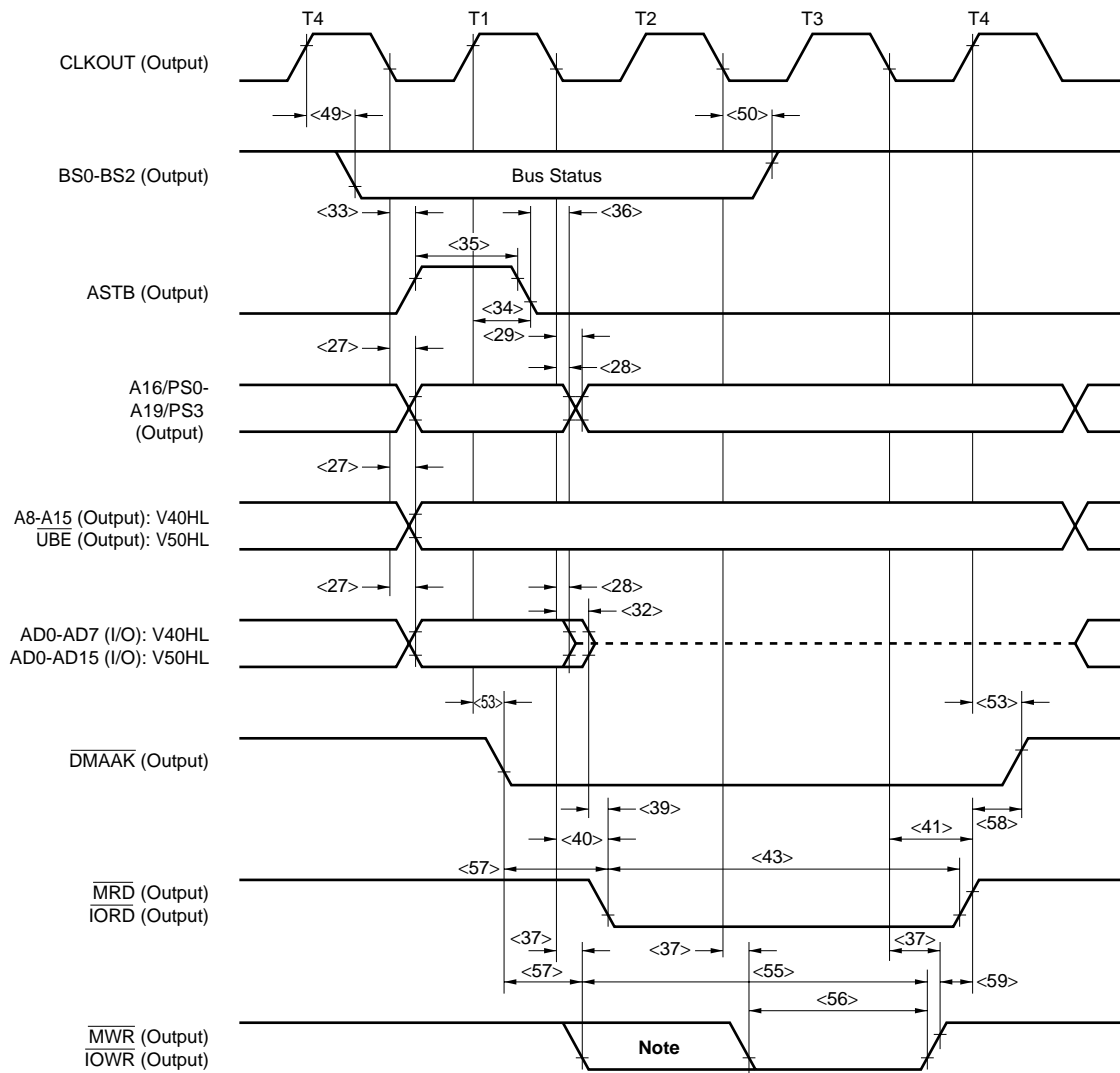

Note Low-level signal is output in extended write mode.

Remark A dashed line indicates high impedance.

DMAU Timing (2)

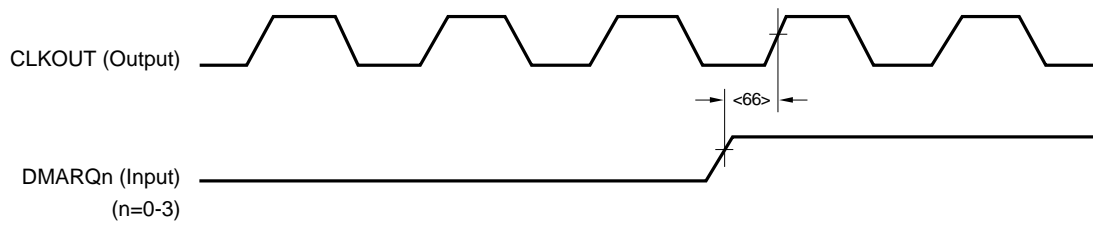
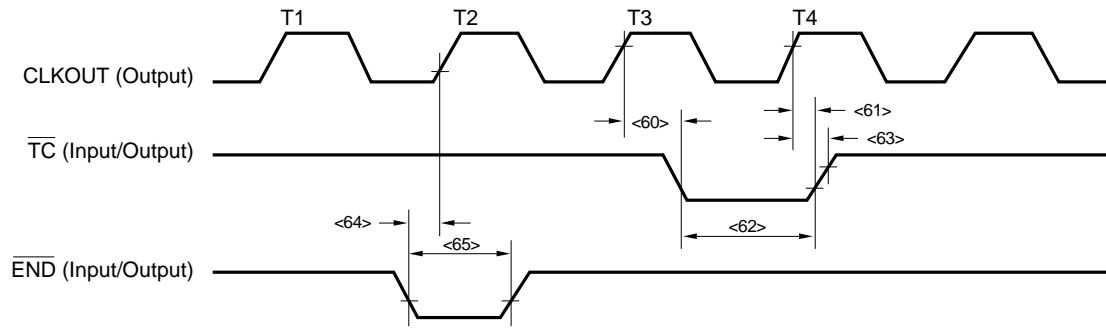

DMAU Timing (3) (Cascade Mode)

In Normal Operation:

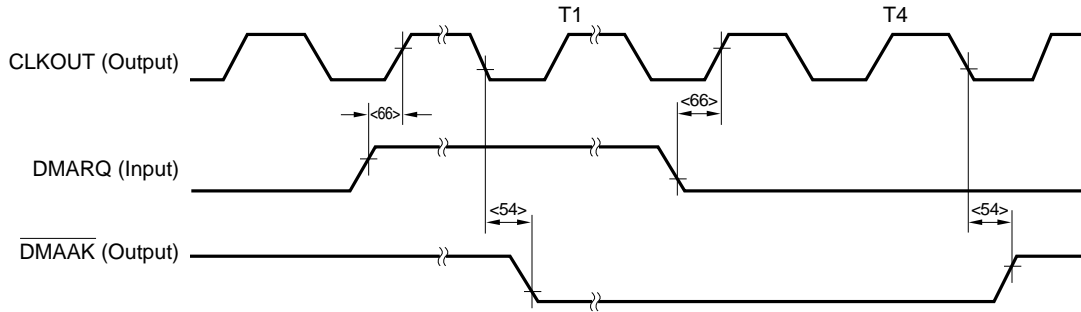

When Refresh Cycle is Inserted:

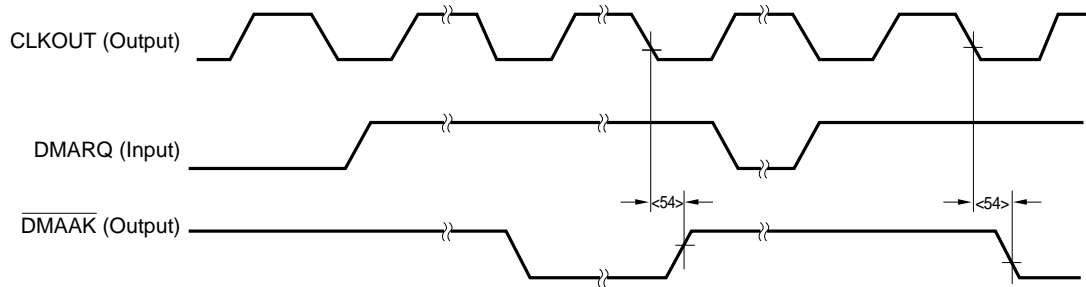

ICU Timing

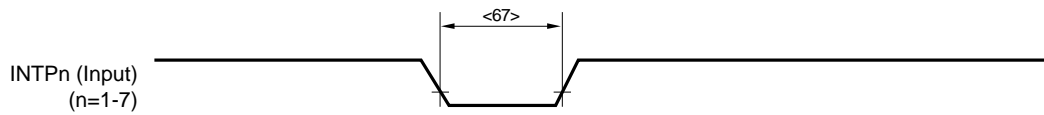

17. PACKAGE DRAWINGS

80 PIN PLASTIC QFP (14x20)

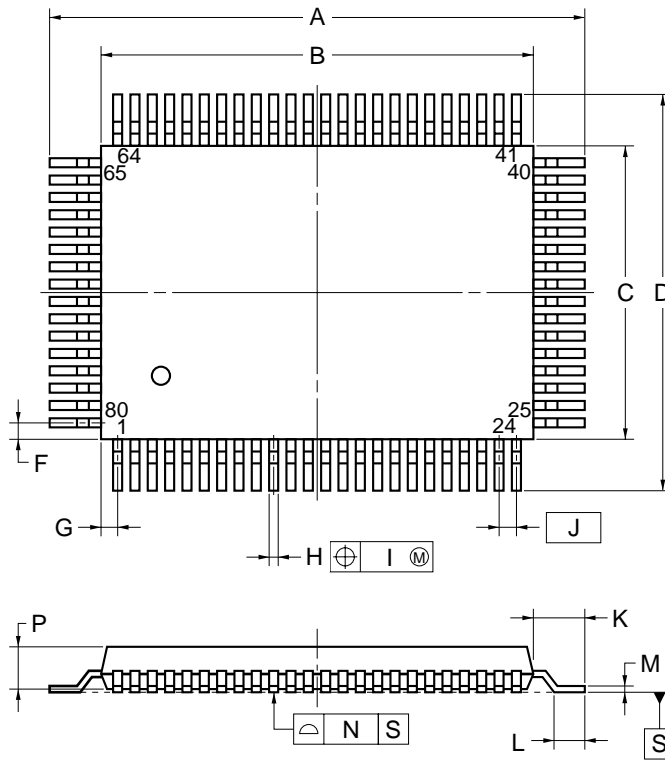

detail of lead end

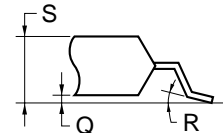

NOTE

1. Controlling dimension — millimeter.
2. Each lead centerline is located within 0.15 mm (0.006 inch) of its true position (T.P.) at maximum material condition.

ITEM	MILLIMETERS	INCHES
A	23.6±0.4	0.929±0.016
B	20.0±0.2	0.795 ^{+0.009} _{-0.008}
C	14.0±0.2	0.551 ^{+0.009} _{-0.008}
D	17.6±0.4	0.693±0.016
F	1.0	0.039
G	0.8	0.031
H	0.37 ^{+0.08} _{-0.07}	0.015 ^{+0.003} _{-0.004}
I	0.15	0.006
J	0.8 (T.P.)	0.031 (T.P.)
K	1.8±0.2	0.071 ^{+0.008} _{-0.009}
L	0.8±0.2	0.031 ^{+0.009} _{-0.008}
M	0.17 ^{+0.08} _{-0.07}	0.007 ^{+0.003} _{-0.004}
N	0.10	0.004
P	2.7±0.1	0.106 ^{+0.005} _{-0.004}
Q	0.1±0.1	0.004±0.004
R	5°±5°	5°±5°
S	3.0 MAX.	0.119 MAX.

P80GF-80-3B9-4

80 PIN PLASTIC TQFP (FINE PITCH) (□12)

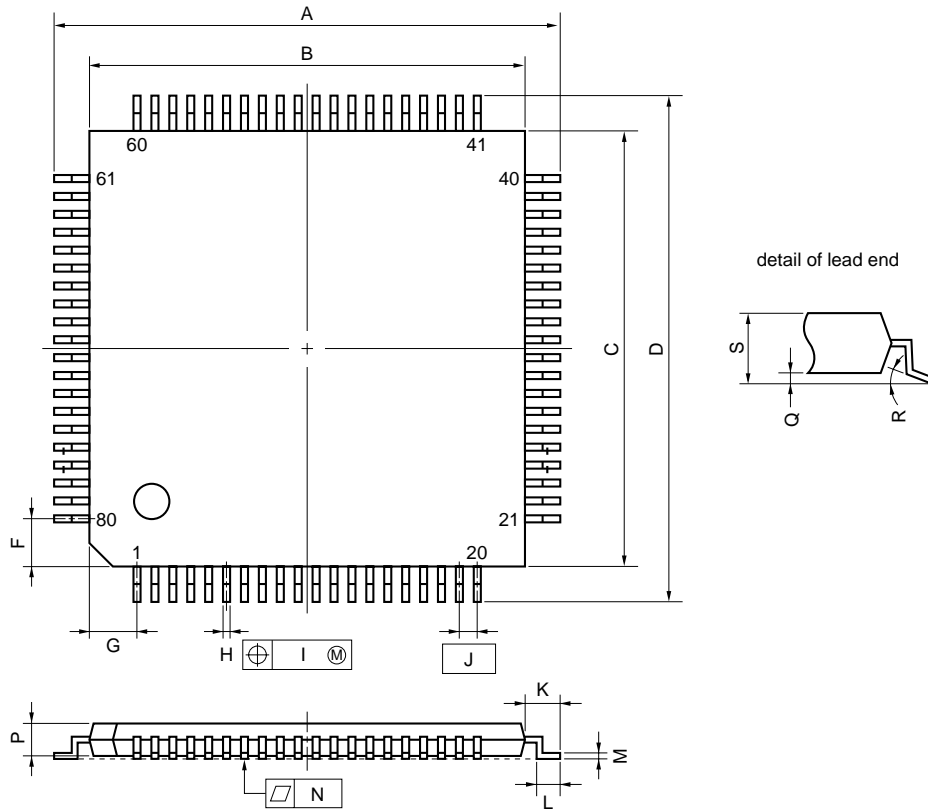

NOTE

Each lead centerline is located within 0.10 mm (0.004 inch) of its true position (T.P.) at maximum material condition.

ITEM	MILLIMETERS	INCHES
A	14.0±0.2	0.551±0.008
B	12.0±0.2	0.472 ^{+0.009} _{-0.008}
C	12.0±0.2	0.472 ^{+0.009} _{-0.008}
D	14.0±0.2	0.551±0.008
F	1.25	0.049
G	1.25	0.049
H	0.22±0.05	0.009 ^{+0.002} _{-0.003}
I	0.10	0.004
J	0.5 (T.P.)	0.020 (T.P.)
K	1.0±0.2	0.039 ^{+0.009} _{-0.008}
L	0.5±0.2	0.020 ^{+0.008} _{-0.009}
M	0.145±0.05	0.006 ^{+0.002} _{-0.003}
N	0.10	0.004
P	1.0±0.05	0.040 ^{+0.002} _{-0.003}
Q	0.1±0.05	0.004±0.002
R	3° ^{+7°} _{-3°}	3° ^{+7°} _{-3°}
S	1.2 MAX.	0.048 MAX.

S80GK-50-9EU

68 PIN PLASTIC QFJ (950 x 950 mil)

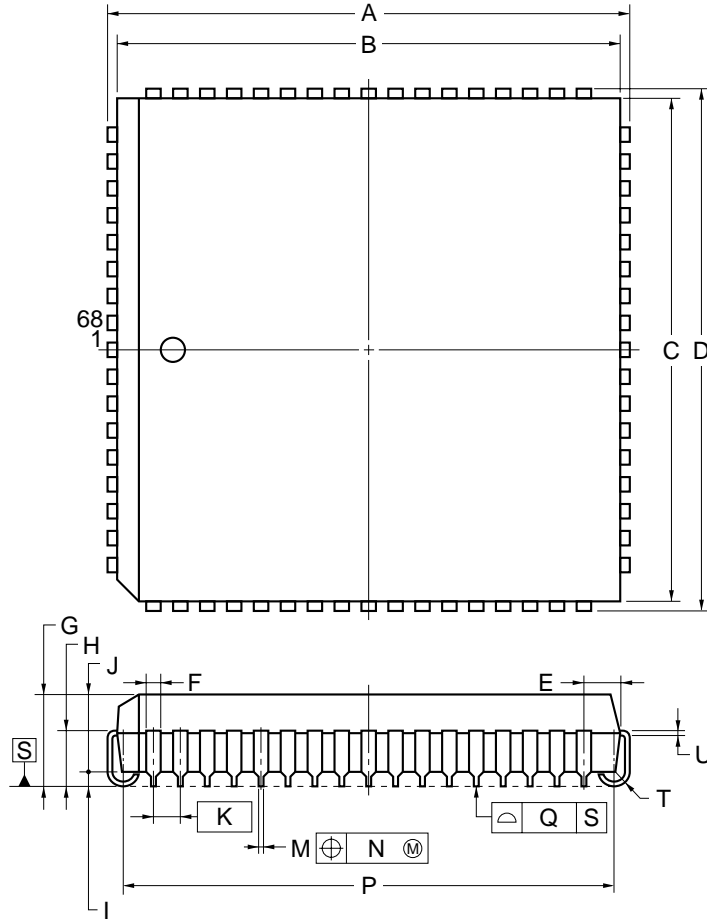

ITEM	MILLIMETERS	INCHES
A	25.2±0.2	0.992±0.008
B	24.20±0.1	0.953 ^{+0.004} _{-0.005}
C	24.20±0.1	0.953 ^{+0.004} _{-0.005}
D	25.2±0.2	0.992±0.008
E	1.94±0.15	0.076 ^{+0.007} _{-0.006}
F	0.6	0.024
G	4.4±0.2	0.173 ^{+0.009} _{-0.008}
H	2.8±0.2	0.110 ^{+0.009} _{-0.008}
I	0.9 MIN.	0.035 MIN.
J	3.4±0.1	0.134 ^{+0.004} _{-0.005}
K	1.27 (T.P.)	0.050 (T.P.)
M	0.42±0.08	0.017 ^{+0.003} _{-0.004}
N	0.12	0.005
P	23.12±0.2	0.910 ^{+0.009} _{-0.008}
Q	0.15	0.006
T	R 0.8	R 0.031
U	0.22 ^{+0.08} _{-0.07}	0.009 ^{+0.003} _{-0.004}

NOTES

1. Controlling dimension — millimeter.
2. Each lead centerline is located within 0.12 mm of its true position (T.P.) at maximum material condition.

P68L-50A1-3

18. RECOMMENDED SOLDERING CONDITIONS

This product should be soldered and mounted under the conditions recommended in the table below.

For the details of recommended soldering conditions for the surface mounting type, refer to the information document **Semiconductor Device Mounting Technology Manual (C10535E)**.

For soldering methods and conditions other than those recommended below, contact our salesman.

Table 18-1. Soldering Conditions

(1) μPD70208HGF-×-3B9 : 80-pin plastic QFP (14 × 20 mm)

μPD70216HGF-×-3B9 : 80-pin plastic QFP (14 × 20 mm)

(a) K, E, X masks

Soldering Method	Soldering Conditions	Recommended Conditions Symbol
Infrared reflow	Package peak temperature : 230 °C, Time: 30 sec. max. (210 °C min.), Number of times: 1, Number of days ^{Note} : 7 days (after this, prebaking is necessary at 125 °C for 10 hours)	IR30-107-1
VPS	Package peak temperature: 215 °C, Time: 40 sec. max. (200 °C min.), Number of times: 1, Number of days ^{Note} : 7 days (after this, prebaking is necessary at 125 °C for 10 hours)	VP15-107-1
Wave soldering	Solder bath temperature: 260 °C max. Time: 10 sec. max., Number of times: 1, Preheating temperature: 120 °C max. (Package surface temperature), Number of days ^{Note} : 7 days (after this, prebaking is necessary at 125 °C for 10 hours).	WS60-107-1
Partial pin heating	Pin temperature: 300 °C max., Time: 3 sec. max. (per device side)	—

(b) P, M masks

Soldering Method	Soldering Conditions	Recommended Conditions Symbol
Infrared reflow	Package peak temperature: 235 °C, Time: 30 sec. max. (210 °C min.), Number of times: 2 max., Number of days ^{Note} : 7 days (after this, prebaking is necessary at 125 °C for 20 hours).	IR35-207-2
VPS	Package peak temperature: 215 °C, Time: 40 sec. (200 °C min.) Number of times: 2 max., Number of days ^{Note} : 7 days (after this prebaking is necessary at 125 °C for 20 hours).	VP15-207-2
Wave soldering	Solder bath temperature: 260 °C max., Time: 10 sec. max., Number of times: 1, Preheating temperature: 120 °C max. (Package surface temperature). Number of days ^{Note} : 7 days (after this, prebaking is necessary at 125 °C for 20 hours).	WS60-207-1
Partial pin heating	Pin temperature: 300 °C max., Time: 3 sec. max. (per device side)	—

Note This means the number of days after unpacking the dry pack. Storage conditions are 25 °C and 65% RH max.

(c) L, F masks

Soldering Method	Soldering Conditions	Recommended Conditions Symbol
Infrared reflow	Package peak temperature: 235 °C, Time: 30 sec. max. (210 °C min.), Number of times: 3 max.	IR35-00-3
VPS	Package peak temperature: 215 °C, Time: 40 sec. (200 °C min.) Number of times: 3 max.	VP15-00-3
Wave soldering	Solder bath temperature: 260 °C max., Time: 10 sec. max., Number of times: 1, Preheating temperature: 120 °C max. (Package surface temperature)	WS60-00-1
Partial pin heating	Pin temperature: 300 °C max., Time: 3 sec. max. (per device side)	—

Caution Do not use one soldering method in combination with another. (however, partial pin heating can be performed with other soldering methods).

- (2) μPD70208HGK-×-9EU : 80-pin plastic TQFP (fine pitch) (12 × 12 mm)
 μPD70216HGK-×-9EU : 80-pin plastic TQFP (fine pitch) (12 × 12 mm)

(a) K, E, X masks

Soldering Method	Soldering Conditions	Recommended Conditions Symbol
Infrared reflow	Package peak temperature : 230 °C, Time: 30 sec. max. (210 °C min.), Number of timers: 1, Number of days ^{Note} : 1 day (after this, prebaking is necessary at 125 °C for 10 hours)	IR30-101-1
VPS	Package peak temperature: 215 °C, Time: 40 sec. max. (200 °C min.), Number of times: 1, Number of days ^{Note} : 1 day (after this, prebaking is necessary at 125 °C for 10 hours)	VP15-101-1
Partial pin heating	Pin temperature: 300 °C max., Time: 3 sec. max. (per device side)	—

(b) P, M, L, F masks

Soldering Method	Soldering Conditions	Recommended Conditions Symbol
Infrared reflow	Package peak temperature: 235 °C, Time: 30 sec. max. (210 °C min.), Number of times: 2 max., Number of days ^{Note} : 7 days (after this, prebaking is necessary at 125 °C for 10 hours).	IR35-107-2
VPS	Package peak temperature: 215 °C, Time: 40 sec. (200 °C min.), Number of times: 2 max., Number of days ^{Note} : 7 days (after this prebaking is necessary at 125 °C for 10 hours).	VP15-107-2
Partial heating	Pin temperature: 300 °C max., Time: 3 sec. max. (per device side)	—

Note This means the number of days after unpacking the dry pack. Storage conditions are 25 °C and 65% RH max.

Caution Do not use one soldering method in combination with another. (however, partial pin heating can be performed with other soldering methods).

- (3) μPD70208HLP-× : 68-pin plastic QFJ (950 × 950 mil)
 μPD70216HLP-× : 68-pin plastic QFJ (950 × 950 mil)

(a) K, E, X masks

Soldering Method	Soldering Conditions	Recommended Conditions Symbol
Infrared reflow	Package peak temperature : 230 °C, Time: 30 sec. max. (210 °C min.), Number of timers: 1, Number of days ^{Note} : 7 days (after this, prebaking is necessary at 125 °C for 36 hours)	IR30-367-1
VPS	Package peak temperature: 215 °C, Time: 40 sec. max. (200 °C min.), Number of times: 1, Number of days ^{Note} : 7 days (after this, prebaking is necessary at 125 °C for 36 hours)	VP15-367-1
Partial pin heating	Pin temperature: 300 °C max., Time: 3 sec. max. (per device side)	—

(b) P, M, L, F masks

Soldering Method	Soldering Conditions	Recommended Conditions Symbol
Infrared reflow	Package peak temperature: 235 °C, Time: 30 sec. max. (210 °C min.), Number of times: 3 max., Number of days ^{Note} : 7 days (after this, prebaking is necessary at 125 °C for 36 hours).	IR35-367-3
VPS	Package peak temperature: 215 °C, Time: 40 sec. (200 °C min.), Number of times: 3 max., Number of days ^{Note} : 7 days (after this prebaking is necessary at 125 °C for 36 hours).	VP15-367-3
Partial pin heating	Pin temperature: 300 °C max., Time: 3 sec. max. (per device side)	—

Note This means the number of days after unpacking the dry pack. Storage conditions are 25 °C and 65% RH max.

Caution Do not use one soldering method in combination with another. (however, partial pin heating can be performed with other soldering methods).

[MEMO]

NOTES FOR CMOS DEVICES**① PRECAUTION AGAINST ESD FOR SEMICONDUCTORS**

Note:

Strong electric field, when exposed to a MOS device, can cause destruction of the gate oxide and ultimately degrade the device operation. Steps must be taken to stop generation of static electricity as much as possible, and quickly dissipate it once, when it has occurred. Environmental control must be adequate. When it is dry, humidifier should be used. It is recommended to avoid using insulators that easily build static electricity. Semiconductor devices must be stored and transported in an anti-static container, static shielding bag or conductive material. All test and measurement tools including work bench and floor should be grounded. The operator should be grounded using wrist strap. Semiconductor devices must not be touched with bare hands. Similar precautions need to be taken for PW boards with semiconductor devices on it.

② HANDLING OF UNUSED INPUT PINS FOR CMOS

Note:

No connection for CMOS device inputs can be cause of malfunction. If no connection is provided to the input pins, it is possible that an internal input level may be generated due to noise, etc., hence causing malfunction. CMOS devices behave differently than Bipolar or NMOS devices. Input levels of CMOS devices must be fixed high or low by using a pull-up or pull-down circuitry. Each unused pin should be connected to V_{DD} or GND with a resistor, if it is considered to have a possibility of being an output pin. All handling related to the unused pins must be judged device by device and related specifications governing the devices.

③ STATUS BEFORE INITIALIZATION OF MOS DEVICES

Note:

Power-on does not necessarily define initial status of MOS device. Production process of MOS does not define the initial operation status of the device. Immediately after the power source is turned ON, the devices with reset function have not yet been initialized. Hence, power-on does not guarantee out-pin levels, I/O settings or contents of registers. Device is not initialized until the reset signal is received. Reset operation must be executed immediately after power-on for devices having reset function.

Regional Information

Some information contained in this document may vary from country to country. Before using any NEC product in your application, please contact the NEC office in your country to obtain a list of authorized representatives and distributors. They will verify:

- Device availability
- Ordering information
- Product release schedule
- Availability of related technical literature
- Development environment specifications (for example, specifications for third-party tools and components, host computers, power plugs, AC supply voltages, and so forth)
- Network requirements

In addition, trademarks, registered trademarks, export restrictions, and other legal issues may also vary from country to country.

NEC Electronics Inc. (U.S.)

Santa Clara, California
Tel: 408-588-6000
800-366-9782
Fax: 408-588-6130
800-729-9288

NEC Electronics (Germany) GmbH

Duesseldorf, Germany
Tel: 0211-65 03 02
Fax: 0211-65 03 490

NEC Electronics (UK) Ltd.

Milton Keynes, UK
Tel: 01908-691-133
Fax: 01908-670-290

NEC Electronics Italiana s.r.l.

Milano, Italy
Tel: 02-66 75 41
Fax: 02-66 75 42 99

NEC Electronics (Germany) GmbH

Benelux Office
Eindhoven, The Netherlands
Tel: 040-2445845
Fax: 040-2444580

NEC Electronics (France) S.A.

Velizy-Villacoublay, France
Tel: 01-30-67 58 00
Fax: 01-30-67 58 99

NEC Electronics (France) S.A.

Spain Office
Madrid, Spain
Tel: 91-504-2787
Fax: 91-504-2860

NEC Electronics (Germany) GmbH

Scandinavia Office
Taeby, Sweden
Tel: 08-63 80 820
Fax: 08-63 80 388

NEC Electronics Hong Kong Ltd.

Hong Kong
Tel: 2886-9318
Fax: 2886-9022/9044

NEC Electronics Hong Kong Ltd.

Seoul Branch
Seoul, Korea
Tel: 02-528-0303
Fax: 02-528-4411

NEC Electronics Singapore Pte. Ltd.

United Square, Singapore 1130
Tel: 65-253-8311
Fax: 65-250-3583

NEC Electronics Taiwan Ltd.

Taipei, Taiwan
Tel: 02-2719-2377
Fax: 02-2719-5951

NEC do Brasil S.A.

Electron Devices Division
Rodovia Presidente Dutra, Km 214
07210-902-Guarulhos-SP Brasil
Tel: 55-11-6465-6810
Fax: 55-11-6465-6829

J99.1

[MEMO]

V20, V20HL, V30, V30HL, V40, V40HL, V50, V50HL and V series are trademarks of NEC Corporation.

- **The information in this document is subject to change without notice. Before using this document, please confirm that this is the latest version.**
 - No part of this document may be copied or reproduced in any form or by any means without the prior written consent of NEC Corporation. NEC Corporation assumes no responsibility for any errors which may appear in this document.
 - NEC Corporation does not assume any liability for infringement of patents, copyrights or other intellectual property rights of third parties by or arising from use of a device described herein or any other liability arising from use of such device. No license, either express, implied or otherwise, is granted under any patents, copyrights or other intellectual property rights of NEC Corporation or others.
 - Descriptions of circuits, software, and other related information in this document are provided for illustrative purposes in semiconductor product operation and application examples. The incorporation of these circuits, software, and information in the design of the customer's equipment shall be done under the full responsibility of the customer. NEC Corporation assumes no responsibility for any losses incurred by the customer or third parties arising from the use of these circuits, software, and information.
 - While NEC Corporation has been making continuous effort to enhance the reliability of its semiconductor devices, the possibility of defects cannot be eliminated entirely. To minimize risks of damage or injury to persons or property arising from a defect in an NEC semiconductor device, customers must incorporate sufficient safety measures in its design, such as redundancy, fire-containment, and anti-failure features.
 - NEC devices are classified into the following three quality grades:
"Standard", "Special", and "Specific". The Specific quality grade applies only to devices developed based on a customer designated "quality assurance program" for a specific application. The recommended applications of a device depend on its quality grade, as indicated below. Customers must check the quality grade of each device before using it in a particular application.
 - Standard: Computers, office equipment, communications equipment, test and measurement equipment, audio and visual equipment, home electronic appliances, machine tools, personal electronic equipment and industrial robots
 - Special: Transportation equipment (automobiles, trains, ships, etc.), traffic control systems, anti-disaster systems, anti-crime systems, safety equipment and medical equipment (not specifically designed for life support)
 - Specific: Aircraft, aerospace equipment, submersible repeaters, nuclear reactor control systems, life support systems or medical equipment for life support, etc.
- The quality grade of NEC devices is "Standard" unless otherwise specified in NEC's Data Sheets or Data Books. If customers intend to use NEC devices for applications other than those specified for Standard quality grade, they should contact an NEC sales representative in advance.